

# Thrane & Thrane A/S

TT-3086A Sailor Fleet55

TT-3084A Sailor Fleet77

Installation Manual

**Document number:** TT98-116875-E

**Release date:** March 15, 2007

Information in this document is subject to change without notice and does not represent a commitment on the part of Thrane & Thrane A/S. It is recommended that the latest version of the manual is downloaded from the Thrane Extra net or requested from the distributor.

## Copyright

© 2007 Thrane & Thrane A/S. All rights reserved. Printed in Denmark.

## Trademark Acknowledgements

- **Inmarsat** is a registered trademark of the International Maritime Satellite Organisation (IMSO) and is licensed by IMSO to Inmarsat Limited and Inmarsat Ventures plc.
- Inmarsat's product names are either trademarks or registered trademarks of Inmarsat.
- Other product and company names mentioned in this manual may be trademarks or trade names of their respective owners.

## Company Addresses

[www.thrane.com](http://www.thrane.com)

### Denmark

**Thrane & Thrane A/S**  
Lundtoftegårdsvej 93 D  
DK-2800 Kgs. Lyngby  
Denmark

T: +45 39 55 88 00  
F: +45 39 55 88 88

### Denmark

**Thrane & Thrane Aalborg A/S**  
Porsvej 2  
DK-9200 Aalborg SV  
Denmark

T: +45 39 55 88 00  
F: +45 96 34 61 01

### USA

**Thrane & Thrane, Inc.**  
509 Viking Drive, Suites K, L and M  
Virginia Beach, VA 23452  
USA

T: +1 (757) 747-2341  
F: +1 (757) 463-9581

### China

**Thrane & Thrane Shanghai  
Representative Office**  
28J Pufa Tower  
588 Pudong Rd(S), Pu Dong  
200120 Shanghai  
P. R. China

T: +86 21 68 87 87 80  
F: +86 21 68 87 71 12

# Safety and Warranty

## General

All cables for the Fleet55/77 system are shielded and should not be affected by magnetic fields. However, if possible do not run cables parallel to AC wiring – failing to do so might cause the equipment to be faulty or working properly.

## Service

User access to the interior of the BDU unit is prohibited. Service may only be performed by a technician authorized by Thrane & Thrane A/S - failing to do so will void the warranty. Access to the interior of the ADU is allowed, but only for replacement of certain modules - as described in this manual. General service may only be performed by a technician authorized by Thrane & Thrane A/S - failing to do so may void the warranty.

## Radar safety distance

Do not move the ADU closer to radars than the minimum safety distance specified in this manual - this will possibly damage the ADU eventually. Equipment must be installed with a minimum safe distance to magnetic steering compass of at least 1.25 m. Personal safe distance is 4 m from the F77 ADU and 2 m from the F55 ADU while it is transmitting.

## Grounding, cables and connections

The BDU unit shall be connected to the ground of the ship via the Antenna Pigtail Cable and the Grounding Kit (Accessories). Further, the BDU must be grounded at its grounding stud.

The ADU shall be grounded to the ship via one or more of its mounting bolts.

The shielded cables must generally be grounded in both ends, except for the cable between BDU and Cradle, which shall not be grounded in the Cradle end.

Connections of all types of equipment must be done while the unit is switched off. For further grounding information read Appendix G *Grounding and RF protection* on page 105.

Do not extend the cables beyond those specified for the equipment – except from the cable between the BDU and ADU. The cable between the BDU and ADU can be extended if it complies with the specified data concerning cable losses etc.

### **Power supply**

Operation voltage is 24 V DC. Note that long-term operation below 24 V DC should be avoided.

It is recommended that the voltage is provided by the ship hot 24 V DC power bus.

Be aware of high start-up peak current. 16 A@24 V, 15 ms.

Maximum operational peak power requirement for F77/F55 is 240/200 W and maximum average power consumption is 180/150 W.

If a 24 V DC power bus is not available, an external 115/230 VAC to 24 V DC power supply can be used.

### **Equipment ventilation**

To ensure adequate cooling of the BDU a 5 cm unobstructed space must be maintained around all sides of the unit (except the bottom side).

BDU ambient temperature range: -15° to +55°C.

**Failure to comply with the rules listed above will void the warranty!**



# Table of Contents

---

<b>Chapter 1</b>	<b>System Units</b>	
	1.1 Introduction .....	1
	1.2 Below Deck Unit - BDU .....	1
	1.3 Display Handset .....	2
	1.4 Distress Cradle .....	2
	1.5 Passive Cradle .....	2
	1.6 Above Deck Unit - ADU .....	2
<b>Chapter 2</b>	<b>GMDSS Installations</b>	
	2.1 Requirements .....	3
	2.2 Distress call initiation .....	3
	2.3 Maritime Safety Information .....	3
	2.4 Power Supply .....	4
<b>Chapter 3</b>	<b>Placing the Antenna</b>	
	3.1 Obstructions .....	7
	3.2 Radiation Hazard .....	8
	3.3 Interference .....	9
	3.4 Antenna Mast Design .....	14
<b>Chapter 4</b>	<b>Installing the ADU</b>	
	4.1 Unpacking .....	19
	4.2 Preparation .....	19
	4.3 Grounding .....	19
	4.4 ADU cables .....	20

4.5	Mounting .....	22
4.6	Important notes .....	22
<b>Chapter 5</b>	<b>Installing the BDU</b>	
5.1	Where to place the BDU .....	23
5.2	Grounding the BDU .....	24
<b>Chapter 6</b>	<b>F77 Distress Cradle</b>	
6.1	Introduction .....	27
6.2	Distress Cradle Assembly .....	28
6.3	Assembly - Default .....	28
6.4	Assembly - Alternative .....	31
<b>Chapter 7</b>	<b>F55 Passive Cradle</b>	
7.1	Introduction .....	33
7.2	Passive Cradle Assembly .....	34
<b>Chapter 8</b>	<b>Connecting Power</b>	
8.1	Power cable selection .....	37
8.2	Power supply specification .....	41
<b>Chapter 9</b>	<b>Setting Up the System</b>	
9.1	Powering Up the System .....	43
9.2	Powering Down the System .....	44
9.3	Service User Menu .....	44
<b>Chapter 10</b>	<b>Hardware Interfaces</b>	
10.1	Overview .....	53

10.2	Analogue 2-wire Interface .....	54
10.3	Cradle/Handset Interface .....	55
10.4	ISDN Interface .....	56
10.5	USB Interface .....	57
10.6	LAN Interface .....	58
10.7	RS-232 Interface .....	59
10.8	NMEA 0183/2000 Interface .....	60
10.9	Discrete I/O interface .....	61
<b>Chapter 11</b>	<b>Service and Repair</b>	
11.1	Introduction .....	63
11.2	Modules .....	63
11.3	Power Supply Module (PSM) .....	65
11.4	High Power Amplifier (HPA) .....	66
11.5	Antenna Control Unit (ACU) .....	67
11.6	Sensor Unit (SU) .....	68
11.7	End Stop Switches (ESS) .....	69
<b>Chapter 12</b>	<b>Troubleshooting</b>	
12.1	Error messages .....	71
12.2	Handset Com Error troubleshooting procedure .....	75
<b>Appendix A</b>	<b>Part numbers</b>	
A.1	TT-3086A Sailor Fleet55 .....	77
A.2	TT-3084A Sailor Fleet77 .....	77
A.3	Sailor Fleet55/77 Antenna Cables .....	78

A.4	Sailor Fleet55/77 Accessories .....	78
A.5	Optional Sailor Fleet55 Cradle Cables .....	79
A.6	Optional Sailor Fleet77 Cradle Cables .....	79
A.7	Optional Sailor Fleet55/77 Cradles & handsets .....	79
A.8	Sailor Fleet55/77 Spare Part Units .....	80
A.9	Sailor Fleet55/77 ADU Spare Parts .....	80

**Appendix B F55/77 ADU Technical Specifications**

B.1	F55 Technical Specifications .....	81
B.2	F77 Technical Specifications .....	83
B.3	F55/F77 Environmental Specifications .....	84
B.4	F55 Outline Dimensions .....	85
B.5	F77 Outline Dimensions .....	86
B.6	Outline Dimensions, Flange .....	87

**Appendix C F55/77 BDU Technical Specifications**

C.1	Technical specifications .....	89
C.2	Outline dimensions .....	92
C.3	Measuring the Ship Source Impedance .....	93

**Appendix D Distress Cradle Technical Specifications**

D.1	Technical specifications .....	95
D.2	Outline Dimensions .....	97

**Appendix E Passive Cradle Technical Specifications**

E.1	Technical Specifications .....	99
E.2	Outline Dimensions .....	100

**Appendix F Handset Technical Specifications**

F.1 Technical Specifications .....103  
 F.2 Outline Dimensions .....104

**Appendix G Grounding and RF protection**

G.1 Why is grounding required? .....105  
 G.2 General about marine DC system .....106  
 G.3 General about marine grounding ..... 108  
 G.4 Grounding Recommendations ..... 110  
 G.5 Alternative grounding for steel hulls ..... 112  
 G.6 Alternative grounding for aluminum hulls ..... 114  
 G.7 Alternative grounding for fiberglass hulls ..... 116  
 G.8 Alternative grounding for timber hulls ..... 118  
 G.9 Separate Ground Cable .....120  
 G.10 RF interference .....125  
 G.11 Electrostatic Discharge .....126

**Glossary** .....127

**Index** ..... 131



# System Units

## 1.1 Introduction

The basic system consists of four units: The Below Deck Unit (BDU), The Control Handset, The Cradle and The Above Deck Unit (ADU).



## 1.2 Below Deck Unit – BDU

The Below Deck Unit (BDU) – which contains the primary electronic parts – is designed for wall or desktop installation. The BDU supplies 42 VDC to the ADU through a single coaxial cable. The F55/F77 BDU power requirement is 240/200 W peak and 180/150 W average at 24 VDC. The power shall be provided by the ship hot 24 VDC power bus, or by an external VAC to VDC power supply (minimum 10A). Be aware of high start-up peak current. 16 A@24 V, 15 ms.

## 1.3 Display Handset

The Display Handset allows dialling and control of the BDU and the antenna.

## 1.4 Distress Cradle

The Distress Cradle, which holds the Display Handset, provides activation of alert transmission. The distress cradle may only be used for F77.

## 1.5 Passive Cradle

The Passive Cradle, which holds the Display Handset, provides no activation of alert transmission. The passive cradle may only be used for F55.

## 1.6 Above Deck Unit – ADU

The antenna (ADU) consists of a stabilized antenna with RF-unit and an antenna control unit, with GPS (ACU). All communication between the ADU and BDU goes through a single coaxial cable. The antenna unit is protected by a fibre glass radome - access to the interior of the ADU is possible through a hatch located at the lower part of the radome.



# *GMDSS Installations*

## 2.1 Requirements

(Not applicable for Fleet55 installations).

The International Maritime Organization (IMO) has set out requirements on how the Fleet77 should be integrated in a Global Maritime Distress and Safety System (GMDSS) installation:

IMO Resolution MSC.130(75).

IMO Resolution A.888(21).

## 2.2 Distress call initiation

For the installation to comply with IMO Resolution (MSC.130/A.3.2), it will need to include a distress cradle and handset fitted on the bridge, as well as in the radio communications room if applicable, for the ability to initiate distress calls.

## 2.3 Maritime Safety Information

The TT-3084A Sailor Fleet77 meets the voice requirements of IMO Resolution A.888(21). To meet the GMDSS carriage requirements of SOLAS (Safety Of Life At Sea) in respect of receipt of SafetyNET broadcasts carrying MSI (Maritime Safety Information) and direct printing telegraphy, it is necessary to install a combined INMARSAT C/EGC transceiver in addition to the INMARSAT F77 equipment.

## 2.4 Power Supply

For the installation to comply with IMO Resolution (MSC.130/A.5.1), a Fleet77 forming part of a GMDSS installation needs to be able to switch between two power supplies, a **main** and a **backup** source, where during main power source failure, the Backup source normally would be automatic switched in and maintain the Fleet77 system fully operational.

A power source change-over unit is not incorporated in the Fleet77 equipment and thus is needed externally.

In principle there are two ways in which the required power supply back up can be obtained:

1. “Hot” connection to the ships emergency batteries.  
In this case the Fleet system is connected “directly” to the batteries and the associated charger, and the charger supplies the power required for the Fleet system. This ensures true “no-break” power supply for the Fleet system. It is of course necessary that the charger is powerful enough to supply the power for the Fleet system, plus other systems which might be connected to the batteries, such that the batteries are not discharged. Be aware of high start-up peak current. 16 A@24 V, 15 ms. Maximum operational peak power requirement for F77/F55 is 240/200 W and maximum average power consumption is 180/150 W.
2. “Cold” or “switch-over” connection to the ships emergency batteries.  
In this case the Fleet system is normally supplied from the ships AC line (115 or 230 V) through an AC to DC (24-28 V) power supply. In case of loss of line voltage the Fleet system power input is, either manually or automatically, transferred to the emergency batteries. In many cases the AC/DC power supply includes battery input and a relay for automatic battery switch-over.

Any interruptions on power sources possibly from power supply switch-over, must be cleared within **60 seconds**, for the Fleet77 to enable automatic power-up and re-initialization. Furthermore, if a power interruption can be kept below 20 ms, it can be guaranteed that a call (e.g. a distress call) will not be disconnected during this. As it could be critical to maintain a call during an emergency situation, it is strongly recommended that the power back-up installation is made such that switch-over takes less than 20 ms.

The AC/DC power supply TT-3680F provided by Thrane & Thrane A/S, is usable for GMDSS installations, and is capable of automatic switch-over to battery power in less than 20 ms.



# Placing the Antenna

## 3.1 Obstructions

The antenna rotates 360° and down to -25° in pitch and roll to allow for continuous pointing even during the worst sea states. Any obstructions within this volume can cause signal degradation.

The amount of degradation depends on the size of the obstruction and the distance from the antenna. As a rule of thumb any obstruction, which subtends an angle of less than 3° at the antenna will have limited effect. The table below gives a guideline for obstruction sizes, which will cause limited degradation.

Distance of Obstruction	Size of Obstruction
3 m	16 cm
5 m	26 cm
10 m	52 cm
20 m	104 cm

### 3.2 Radiation Hazard

The F77 antenna radiates 32 dBW EIRP (including 20 dBi antenna gain). This translates to a minimum safety distance of 4 m from the antenna while it is transmitting. This is based on a radiation level of 0.8 mW/cm<sup>2</sup>. The F55 antenna has a safety distance of 2 m.

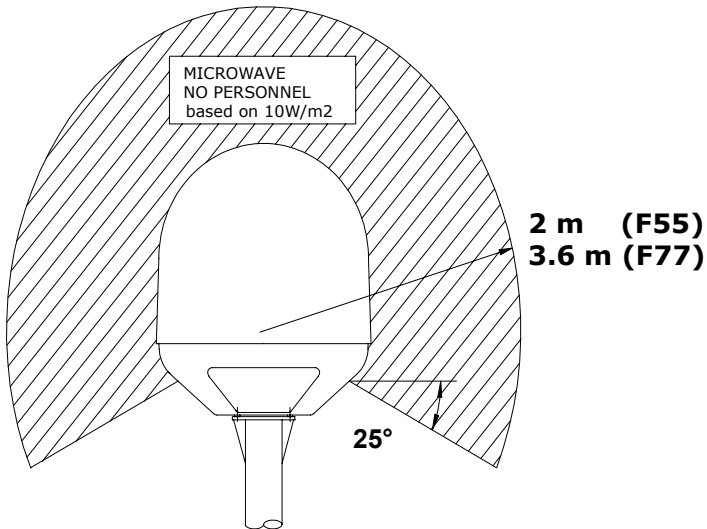

For higher radiation level, see the table below.

Radiation level	F55 Distance	F77 Distance
100 W/m <sup>2</sup>	0.6 m	1.1 m
25 W/m <sup>2</sup>	1.1 m	2.3 m
10 W/m <sup>2</sup>	2.0 m	3.6 m

## 3.3 Interference

The ADU (antenna) must be mounted as far away as possible from the ship's radar and high power radio transmitters (including other Inmarsat based systems), as these can compromise the ADU performance. RF emission from radars might actually damage the ADU.

As the Fleet ADU itself is a quite powerful transmitter, this on the other hand is also capable of disturbing other radio systems. Especially, other Inmarsat systems and GPS receivers with poor frequency discrimination are vulnerable to the radiation generated by the Fleet ADU.

### 3.3.1 Radar

It is difficult to give exact guidelines for minimum distance between a radar and the ADU – as radar power, radiation pattern, frequency and pulse length/shape varies widely from radar to radar. Further, the ADU will typically be placed in the near field of the radar antenna and reflections from masts, decks and other items present in the vicinity of the radar will be different from ship to ship.

Despite the issues mentioned above, the guidelines below can be given:

Since a radar radiates a fan beam with a horizontal beam width of a few degrees and a vertical beam width of up to  $\pm 15^\circ$ , the worst interference can be avoided by mounting the ADU at a different level – meaning that the ADU is installed minimum  $15^\circ$  above or below the radar antenna. Due to near field effects the benefit of this vertical separation could be reduced at short distances (below approximately 10 m) between radar antenna and ADU. Therefore it is recommended to ensure as much vertical separation as possible when ever the ADU has to be placed close to a radar antenna.

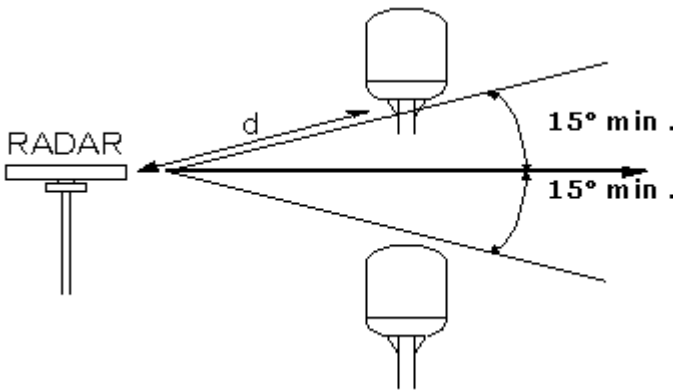



### 3.3.2 ADU damage

The minimum acceptable separation (d min.) between a radar and the ADU is determined by the radar wavelength/frequency and the power emitted by the radar. The tables below show some “rule of thumb” minimum separation distances as a function of radar power at X and S band. If the “d min.” separation listed below is applied, ADU damage will normally be avoided.

“d min.” is defined as the shortest distance between the radar antenna (in any position) and the surface of the Fleet ADU.

<b>X-band (~ 3 cm / 10 GHz) damage distance</b>		
Radar power	d min. at 15° vertical separation	d min. at 60° vertical separation
0 – 10 kW	0.8 m	0.4 m
30 kW	2.4 m	1.2 m
50 kW	4.0 m	2.0 m

<b>S-band (~ 10 cm / 3 GHz) damage distance</b>		
Radar power	d min. at 15° vertical separation	d min. at 60° vertical separation
0 – 10 kW	0.4 m	0.2 m
30 kW	1.0 m	0.5 m
50 kW	2.0 m	1.0 m

The separation distance for C-band (4-8 GHz) radars should generally be the same as for X-band radars.

### 3.3.3 Interference

At distances further away than “d min.” given above the radar might still be able to degrade the performance of the Fleet system.

The presence of one or more X-band radars within a radius up to around 100 m could cause a minor degradation of the signal to noise ratio during high speed and data calls. The degradation will be most significant at high radar pulse repetition rates.

As long as receiving conditions are favorable, this limited degradation is without importance. However, if receiving conditions are poor – e.g. due to objects blocking the signal path, heavy precipitation or icing, low satellite elevation and violent ship movements – the small extra degradation due to the radar(s) could cause poor call quality. A speech call might become noisy and perhaps fail while a data connection might decrease in speed and performance.

The presences of S-band radar(s) are unlikely to cause any performance degradation – as long as the minimum distances (d min.) listed above are applied.

It is strongly recommended that interference free operation is verified experimentally before the installation is finalized.



**Warning!** The ADU must never be installed closer to a radar than “d min.” - even if experiments show that interference free operation can be obtained at shorter distances than “d min.” given above.

### 3.3.4 Other Inmarsat systems

Recommended minimum safe distance to other Inmarsat antennas is 10 m.

### 3.3.5 GPS receivers

Good quality GPS receivers will work properly very close to the ADU - typically down to one meter outside the main beam, and down to a few meters inside

the main beam. However, simple GPS receivers with poor frequency discrimination could be affected at longer range (typically 10 m). It is always recommended to test the GPS performance before the installation is finalized.

### 3.3.6 Other transmitters

See *Minimum Recommended Distance to Transmitters*, on page 88 in Appendix B for minimum recommended distance to transmitters in the frequency range below 1000 MHz.

### 3.3.7 Other precautions

Do not place the ADU close to a funnel, as smoke deposits are corrosive. Furthermore, deposits on the radome can degrade performance.

## 3.4 Antenna Mast Design

The antenna mast must be designed to carry the weight of the antenna unit, which for F55 is approximately 18 kg and for F77 is approximately 27 kg.

It must also be able to withstand wind forces up to 140 knots on the radome as well as onboard vibrations.

The top of the antenna mast should be fitted with a flange with holes matching the bosses in the radome. The flange diameter must be less than 380 mm in order to avoid interference with the F77 hatch and the antenna beam.

The flange thickness must be at least 10 mm. The antenna is to be mounted on the flange by means of 4 M10 bolts. The bolt engagement shall be  $15 \pm 5$  mm. Drill a hole in the centre of the flange for radome drain pipe.

See *Outline Dimensions, Flange* on page 87 in Appendix B.

The holes in the flange must be positioned symmetrically around the longitudinal axis of the ship, to ensure the correct heading of the antenna. See Appendix B *F55/77 ADU Technical Specifications* on page 81 for heading mark.

The Antenna tracking system is directional why the heading direction of the ADU is extremely important, as setting the wrong heading will cause the antenna to lose track of the satellite as soon the ship start to move.

In some cases it may be necessary to install the antenna such that it is misaligned to the ship, e.g. to insure F77 hatch accessibility. Compensation for mount pos can only be done in steps of  $90^\circ$ . See User Manual chapter 4 “Ant. Setup”. Antenna Set-up for installation angle set-up in case the angle is different from the default  $0^\circ$ .

The F55/F77 heading is defined by the ADU N-type connector placement. For the F77 the hatch may be used for locating the heading direction as well.

**Bottom View**

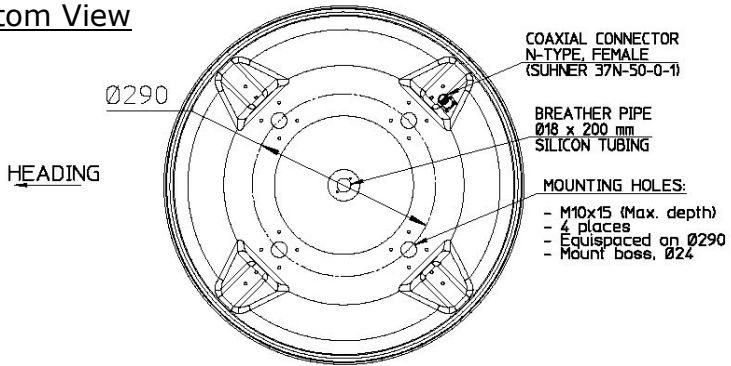

The F55/F77 value of the installation angle is defined as shown below (seen from above ship).

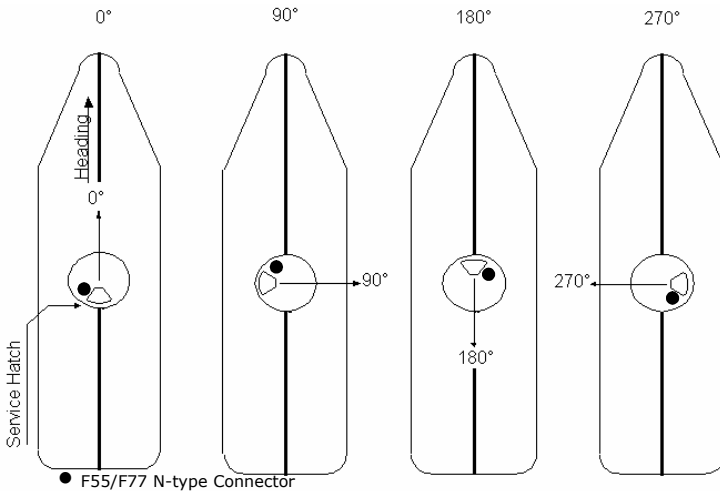

Long-term, trouble free operation depends on good mast design avoiding severe shocks and vibration levels. As every ship has unique structural characteristics, it is difficult to give specific design rules. Nevertheless, every attempt should be made to design a mast which has a natural frequency >25 Hz (i.e. stiff) to avoid the majority of the ships vibration spectrum.

The table below gives some suggested design values for the free part of the pole mast.

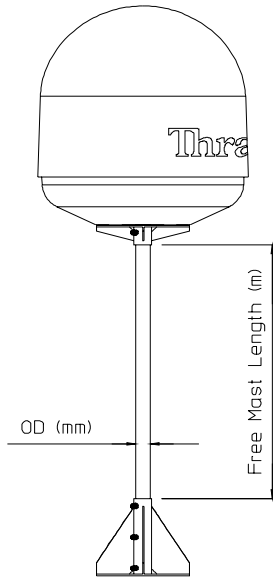

OD (mm)	Wall Thickness (mm)	Max. free mast length (m)			
		Steel		Al	
		F55	F77	F55	F77
100	2.5	0.8	0.6	0.5	0.4
	5	1.0	0.8	0.7	0.5
150	3.75	1.4	1.2	1.0	0.8
	7.5	1.6	1.4	1.3	1.0
200	5	2.0	1.7	1.5	1.3
	10	2.1	1.9	1.8	1.6
250	3.25	2.2	2.0	1.7	1.5
	12.5	2.5	2.3	2.2	2.0
300	7.5	2.7	2.6	2.4	2.2
	15	2.8	2.7	2.6	2.4

High masts or installations on ships with high vibration levels should be further stabilized by stays from the mast flange.

**Note**

Stays and stiff masts can still not prevent vertical vibration if the mast is attached to a deck plate that is not stiff. Every effort should be made to mount the mast to an area that is well supported by ribs. If this is not possible, extra deck plate stiffening should be provided.





# *Installing the ADU*

## 4.1 Unpacking

Open all boxes supplied and check the contents with the enclosed packing list. Inspect units and parts for possible transport damage.

## 4.2 Preparation

The antenna is supplied in a cardboard box and is bolted to a pallet. Cut the straps around the sides, remove the lid and take the sides off by lifting over the radome. The antenna system can be removed from the pallet by removing the 4 M10 screws from underneath.

## 4.3 Grounding

It is recommended that the antenna is grounded via its mounting bosses to its mounting plate as the RF coax screen and antenna electronics ground are referenced to this point.

The metal underneath the head of **at least** one bolt must be clean of insulating protective coating and a serrated washer should be used. After the bolts are tightened, it is recommended that the area is suitably sealed in order to avoid corrosion of the grounding point.

It is recommended that all 4 bolts are used for grounding. Use stainless steel bolts and washers.

For further grounding information read Appendix G *Grounding and RF protection* on page 105.

## 4.4 ADU cables

The coaxial cable for connection between the antenna and BDU is **not** part of the basic system. Make sure that a sufficient length of cable is ordered. See Appendix A *Part numbers* on page 77 for cable options.

Select a suitable area for installation of the BDU, ADU and Cradle. Where exposed to mechanical wear - on deck, through bulkheads, etc. - steel pipes should protect the cables. Standard procedures should otherwise be followed for cabling in ship installations.

The maximum allowed RF-loss in the Antenna cable is 10dB@1660 MHz. This is to ensure the performance of the system. The Cable loss can be read in the handset.

The Cable loss readout will vary mainly due to Temperature changes in the ADU. In Table 1 below, the maximum allowed Cable loss readout are listed.

ADU temp.	-25°C	+22°C	+65°C
Max allowed Cable loss readout	80%	88%	95%

Table 1: Maximum allowed Cable loss readout vs. ADU Temp.

During installation the Cable loss readout shall be checked. If the Cable loss readout is above the specified maximum values the installation has to be checked.

## Recommended Antenna Cables:

Cable Type	Absolute maximum length
RG214U	25 m
02Y(st)C2YC 2.7/7.3AF	50 m
SA07272 (TT-116689)	50 m
SA12272 (TT-108740-060)	60 m
LCF12-50J	100 m

Furthermore it has to be checked in the data sheet from the cable supplier, that both the RF-attenuation and the DC-resistance are kept within the maximum specified values:

- Antenna Cable RF-attenuation max: 10 dB excl. connector.
- Antenna Cable loop DC-resistance max: 0.54  $\Omega$ .

Also it has to be ensured that the specified minimum bending radius is respected. If this is not the case, the loss in the cable will increase. Check the instruction from the cable supplier.

The coax cable can be extended if it complies with the specified losses listed below.

- Maximum RF loss, 1525 - 1660 MHz: 10 dB
- Maximum DC loss, R loop: 0.54  $\Omega$
- Maximum RF loss, 3.5 - 4.0 MHz: 2 dB

## 4.5 Mounting

The radome can now be installed on the mounting plate on the ship via 4 M10 stainless steel bolts. In case of F77 the hatch must face the stern of the ship.

If it is necessary to alter the mount position relative to the ship (90, 180 or 270°, and to ensure hatch accessibility), the “mounting pos” has to be adjusted, this can be done via the Display Handset.

See User Manual chapter 4. “Ant. Set-up” for “mounting pos” adjustment.

The only electrical connector is a single N-Type connector on the lower radome.

## 4.6 Important notes

Do not re-use any of the M10 screws from the pallet. The bolt thread must not penetrate more than 20 mm - and not less than 10 mm - into the bosses of the radome. The bolts must be tightened to  $25 \pm 5$  Nm.

After having connected the antenna cable to the ADU - ensure that the connector assembly is properly protected against seawater and corrosion. As a minimum, it is recommended that self-amalgamating rubber tape is used.

## Installing the BDU

### 5.1 Where to place the BDU

The BDU must be placed in a ventilated area. To ensure adequate cooling of the BDU a 5 cm unobstructed space must be maintained around all sides of the unit (except the bottom side).

Ambient temperature range is  $-15^{\circ}$  to  $+55^{\circ}\text{C}$ .

The BDU is manufactured as a cabinet for bulkhead or desktop installation. The cabinet is equipped with two mounting brackets, which makes it possible to secure the unit on a bulkhead.

See *Outline dimensions* on page 92 in Appendix C.



#### Note

It is very important that the BDU is placed in an area where access to the hull or equivalent grounding can be reached within **0.5 m**.

The BDU and all external units delivered by Thrane & Thrane A/S must be placed with a minimum safe distance of at least **1.25 m** to magnetic steering compass.

The unit that has the largest impact on magnetic steering compasses is the distress cradle, since it contains a magnet, which holds the display handset.

Minimum safe distance is 1.25 m – but if possible, place the distress cradle/handset further away from magnetic steering compasses.

## 5.2 Grounding the BDU

The antenna cable (4) is connected to the BDU by means of a coax “pigtail” (3).

The pigtail is connected to the BDU by a TNC-connector (male) and to the antenna cable by an N-connector (female). The pigtail must be grounded at the N-connector end – use the grounding kit (2) to mount the cable on the hull or other common ground.

To ensure that the BDU is grounded – also if the pigtail is disconnected from the BDU, an extra ground wire must be connected. The ground wire is connected to the BDU by an M3x6 screw. The grounding point is located next to the power plug (1).

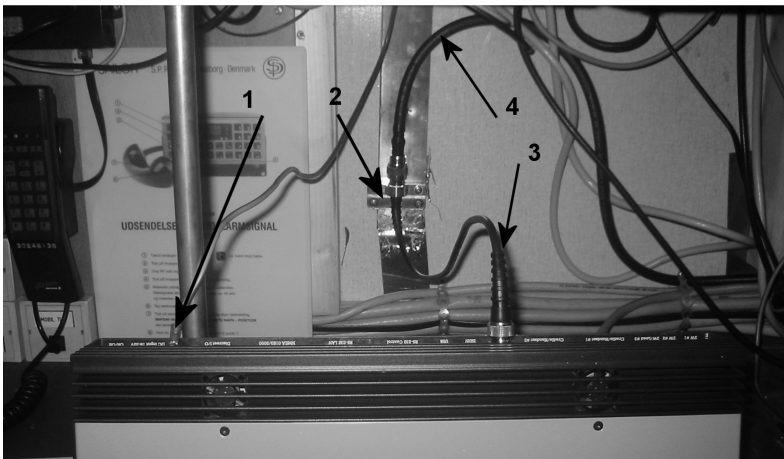

In some cases it is not possible to access the hull and at the same time place the BDU in a suitable place.

The pigtail is only 0.5 m long and extension is not allowed.

A way to insure good grounding and at the same time make it possible to ground the pigtail - is to extend the ship ground plan by means of copper foil. The maximum length of the foil is determined by the width of the foil.

Copper foil 5 cm wide: Max 50 cm

Copper foil 10 cm wide: Max 100 cm

Copper foil 20 cm wide: Max 200 cm

**Note** | The foil must be at least 0.1 mm thick.

Connect the foil to the hull by plenty of screws or hard-soldering. Run the foil past the place where the pigtail is to be grounded and mount the grounding kit on top of the foil.

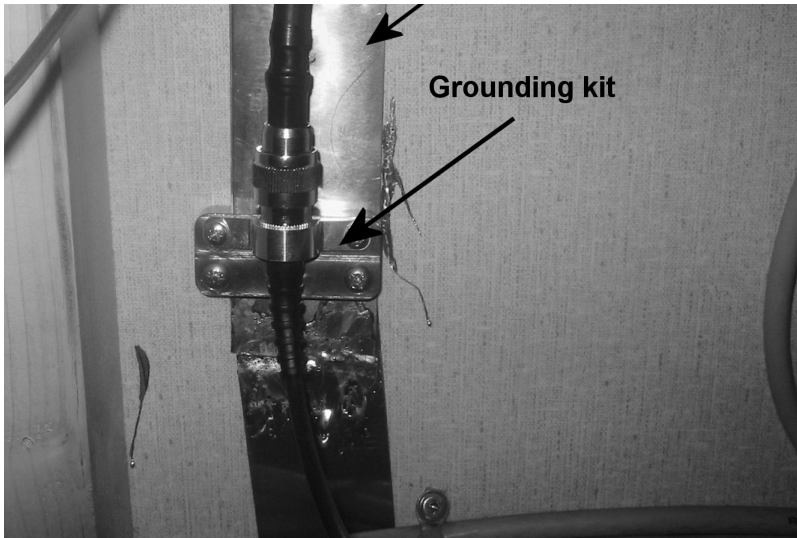

For further grounding information read Appendix G *Grounding and RF protection* on page 105.





# *F77 Distress Cradle*

## 6.1 Introduction

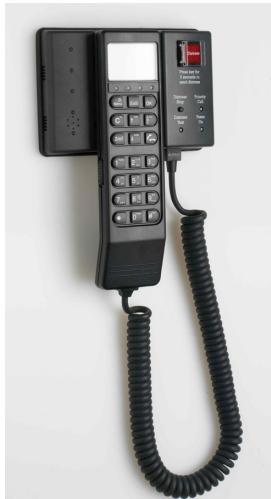

The Distress Cradle/Handset is used for F77 and can be placed anywhere onboard the ship.

The only limitations are:

- Maximum cable length (do not extend the cable): 40 m.
- Minimum safe distance to magnetic steering compass: 1.25 m.

Note that no special grounding of the Distress Cradle/Handset is required.

## 6.2 Distress Cradle Assembly

Since the cable between the Distress Cradle and BDU is not part of the basic system - the Distress Cradle is not fully assembled when the system is shipped.

Select a suitable cable (see Appendix A) - and assemble the Distress Cradle as described below.

## 6.3 Assembly - Default

The assembly instruction described is for installation, where the cable runs though the wall behind the cradle.

Start by wrapping the edging rubber gasket around the medium plate.

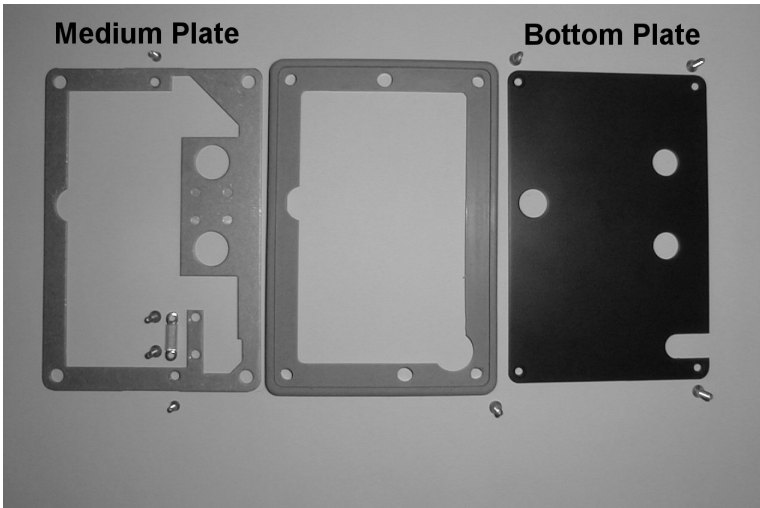

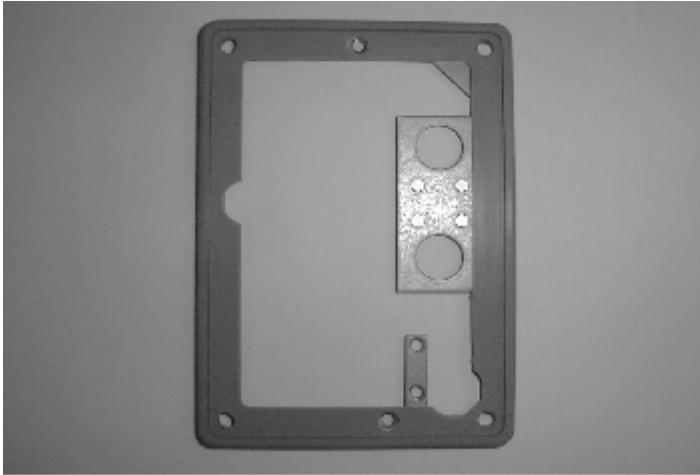

Place the cable in the cable suspender and slightly tighten the screws (1).

Mount the plate and tighten the screws (2).

Plug the cable in J3 (3).

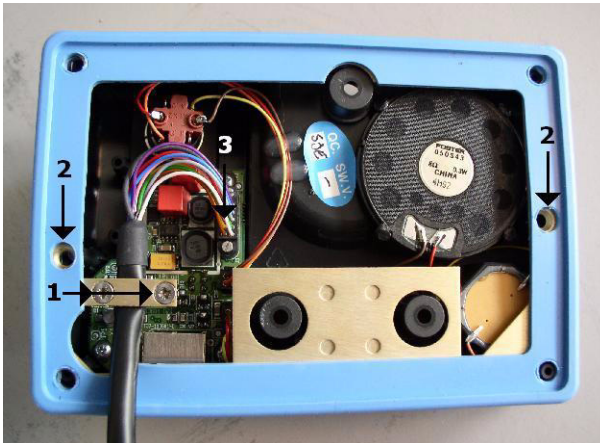

Finally slide the grommet into the slot in the bottom plate and mount the plate and tighten the screws (3).

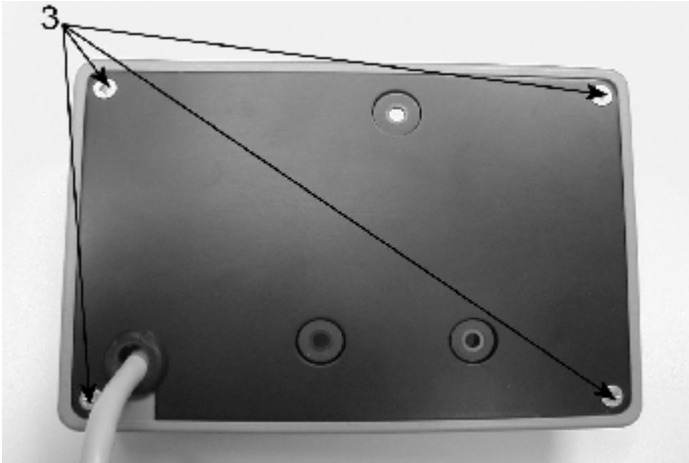

## 6.4 Assembly – Alternative

The assembly instruction described below is meant for installation, where the cable runs on a bulkhead.

Cut out the area shown.

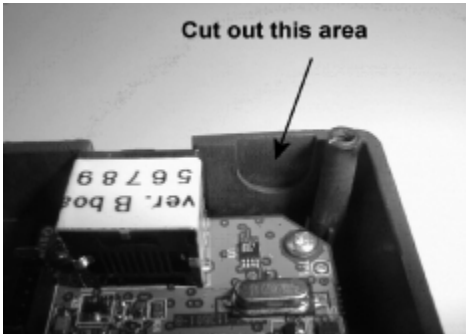

Slide the grommet into the cradle slot – and finalize the assembly as described.





## *F55 Passive Cradle*

### 7.1 Introduction



The passive Cradle/Handset is used for F55 and can be placed anywhere on board the ship.

The only limitations are:

- Maximum cable length (do not extend the cable): 40 m.
- Minimum safe distance to magnetic steering compass: 1.25 m.

Note that no special grounding of the Cradle/Handset is required.





Place the Circuit board in the Cradle, connect the cable and secure the cable using the relieving clamp.

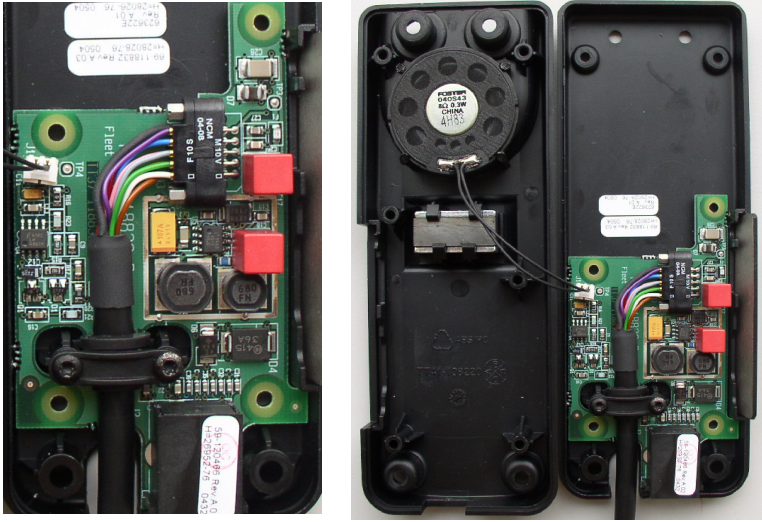

Connect the speaker and insert the blind plate.

Assemble the upper and lower cradle part using the self tapping screws.  
Mount the cradle and cover the mounting holes using the four blind plugs.

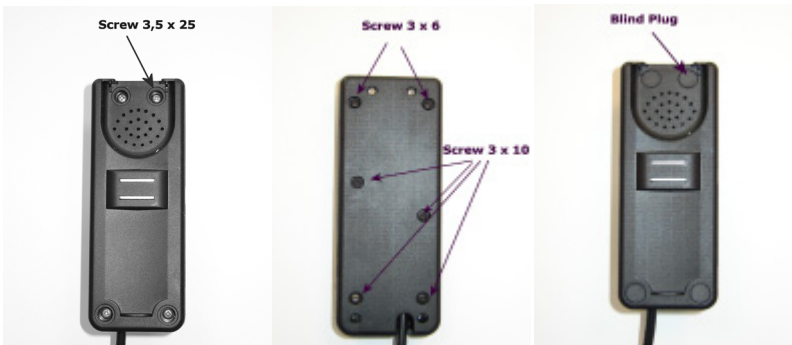



# Connecting Power

## 8.1 Power cable selection

The length of the BDU power cable depends on the type of cable used and the source impedance of the ship's 24 V DC installation. It is required that the total source impedance at the BDU does not exceed 250 m $\Omega$ .

Select a power outlet from the ship's 24 V DC system, and measure the source impedance of the ship installation as described in *Measuring the Ship Source Impedance* on page 93 in Appendix C.

If a 50 m $\Omega$  ship source impedance is measured, only 200 m $\Omega$  is left for power cable loop resistance, since the total source impedance should be below 250 m $\Omega$  (250 m $\Omega$  - 50 m $\Omega$  = 200 m $\Omega$ ).

**Note**

If the total source impedance is higher than 250 m $\Omega$ , the terminal may start to On/Off oscillate.

For further recommendations on power cable selection, see the appropriate section on the next page, depending on which power connector the BDU is fitted with:

- BDU fitted with the old 4-Port power connector: See section 8.1.1 *Old 4-port power connector*.
- BDU fitted with the new Sub-D power connector: See section 8.1.2 *New Sub-D power connector*.

### 8.1.1 Old 4-port power connector

(Only applicable for old 4-port power connector).

To make sure that the power cable fits the power connector the dimensions of the cable must be:

- Cable outer diameter max 3 mm
- Inner core 1.5 mm<sup>2</sup>

The cable inductance should not exceed 5 μH. If the inductance is too high, the power supply may start to oscillate.

To minimize the cable inductance a multi 2- or 4-wire cable should be used.

Recommended power cable types and length:

Cable Type	Length from source. Source imp. < 50 mΩ	Length from source. Source imp. < 100 mΩ
2 x 1.5 mm <sup>2</sup>	0 - 10 m	0 - 7 m
2 x 2 x 1.5mm <sup>2</sup>	10 - 20 m	7 - 14 m
Use local AC:DC converter.	> 20 m	> 14 m

The power connector has the option of running four cables instead of two, which allows the cable to be twice as long.

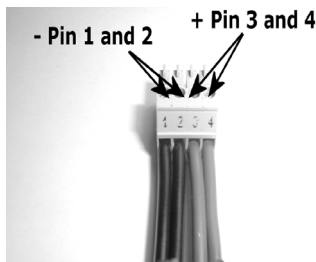

Cables with larger cross-section area than  $1.5 \text{ mm}^2$  may be connected to the BDU by use of the pigtail that is supplied with the system.

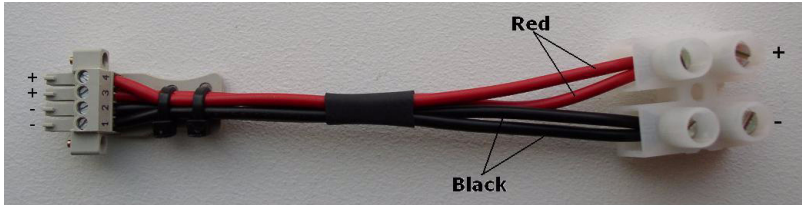

By use of this pigtail, you may extend the cable length as long as you keep the total source impedance  $< 250 \text{ m}\Omega$  and cable inductance  $< 5 \text{ }\mu\text{H}$ .

The BDU is equipped with an internal 10 A thermal circuit breaker, therefore no external fuse is necessary in order to protect the BDU. However, in order to avoid short circuit in the power cable/connector, the ships DC outlet should be protected by a 10-15 A fuse or circuit breaker. If the automatic circuit breaker pops out check the power supply polarisation.

### 8.1.2 New Sub-D power connector

(Only applicable for new Sub-D power connector).

The BDU is delivered with a 1.5 m power cable; this can be extended according to the recommendations below:



Cable Type	Length from source. Source imp. < 50mΩ	Length from source. Source imp. < 100mΩ
4 mm <sup>2</sup> (AWG11)	0 - 20 m	0 - 15 m
10 mm <sup>2</sup> (AWG8) <sup>a</sup>	20 - 50 m	15 - 35 m
Make sure that cable meets inductance requirements. <sup>a, b</sup>	> 50 m	> 35 m

- a. When extending the power cable; positive and negative supply wires must be installed closely together side by side to keep cable inductance low.
- b. Ensure that cable inductance for the selected cable at the desired length is below the 50 μH requirement.

The BDU is equipped with an internal 15 A Fuse, therefore no external fuse is necessary in order to protect the BDU. However, in order to avoid short circuit in the power cable/connector, the ships DC outlet should be protected by a 15-20 A fuse or circuit breaker.

## 8.2 Power supply specification

Voltage: 24 V DC -10%/+30% floating

Power: 240 W

Peak current: 16 A@24 V 15 ms (start up)





# Setting Up the System

## 9.1 Powering Up the System

The power button on the Fleet55 and Fleet77 is placed on the back panel. See figure below.



↑  
Power Button

Press and hold the power button for a few seconds or until the green LED on the front of the terminal, and the handset display, light up. Then release the button.



↑  
Power LED

## 9.2 Powering Down the System

Press and hold the power button for a few seconds, while the handset display shows the message shown below.



Let go of the button when the display shows the message below, and the green LED on the front of the terminal starts flashing.



**Note**

Wait at least 5 seconds after a power down, before trying to power up the F55 or F77 again.

## 9.3 Service User Menu

Before the system is ready to make the first call – some basic system configuration is necessary.

The system configuration is carried out by the Service User, who has access to all functionality in the BDU Unit.

The system configuration can be done via the handset or by running the FleetCp program from a PC connected to the BDU.

See User Manual chapter 5, System Set-up from PC.

All configuration information is stored in the configuration module. It takes approximately 10 sec. for the system to update and store configuration information. When configuration information is changed or added **wait min. 10 sec. before powering down the system.**

The below drawing shows the Service User menu.

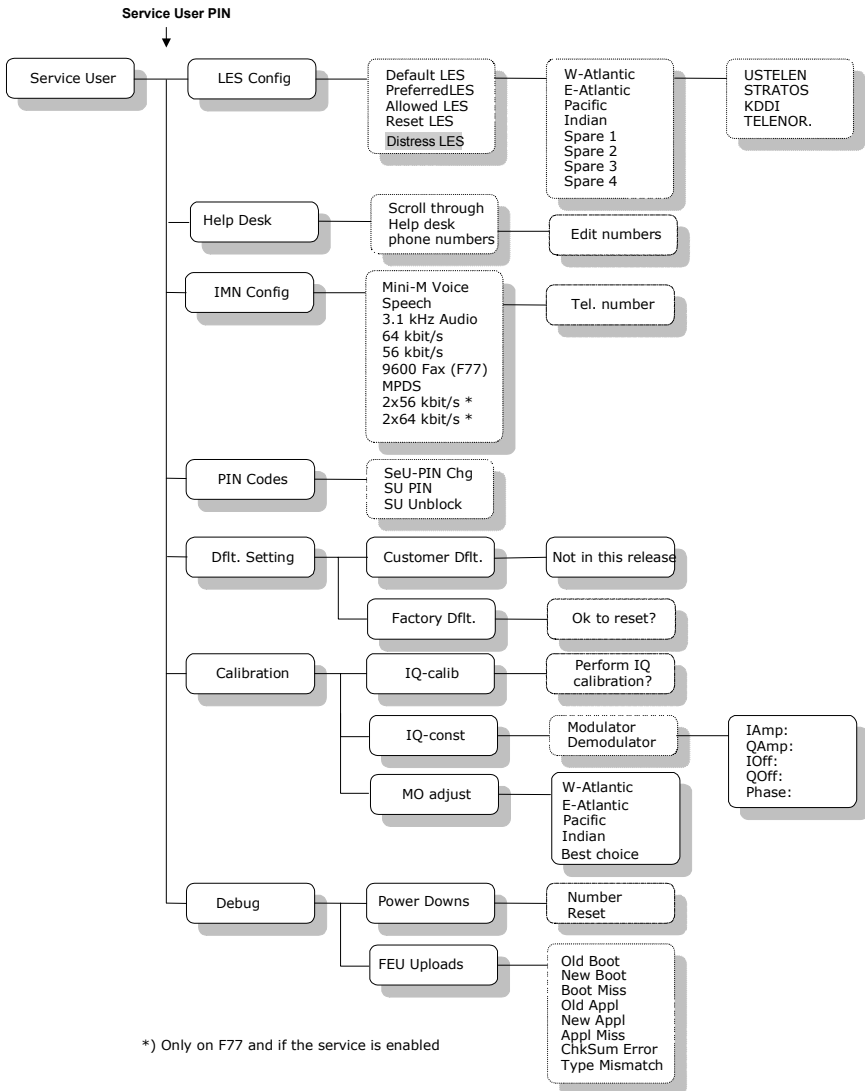

See also User Manual chapter 3, Use of PIN codes.

## 9.3.1 LES Config

### Overview









This menu is used to select a list of LES operators. It contains the following sub menus:







- Default LES
- Preferred LES
- Allowed LES
- Reset LES
- Distress LES (Only F77)

“Allowed LES” is the only menu that is special to the Service User menu. For the description of the other LES Config sub menus you are referred to the “TT-3084A Sailor Fleet77, TT-3086A Sailor Fleet55, User Manual”

### Allowed LES selection

An Allowed LES list can be selected under the Service User menu. The Service User/supplier can decide which LES's are allowed to be used in the selected ocean region.

1. From the main menu select Service User by pressing  or  and press .
2. Type the Service user PIN code and press  to enter the Service user menu.
3. Select LES Config by pressing  or  and press .
4. Select Allowed LES and press .
5. Selected ocean region and press .

6. A list of all LES's should appear for each LES intended to be on the list press  .
7. Press  to update allowed LES.
8. To remove a LES from the list, press   and then  to update the list.

This configuration must be done for each Ocean Region.

Only the LES's marked in the Allowed LES list can be selected as Default or Preferred LES.

If no Allowed LES's are selected all LES's are accessible.

It is now Preferred LES list that decides which LES's that can be used as Default LES.







## 9.3.2 Help Desk









The Help Desk menu can be used to select and initiate calls to certain numbers, which may provide help in case you have forgotten your PIN code.

Editing/inserting and deleting entries can only be done from the service user menu.

Each entry contains a name, phone number of the entry, TNID (terrestrial network ID) and a LES access code.

### Inserting a number

1. From the main menu select Service user by pressing   or   and press .
2. Type the Service User PIN code and press  to enter the Service User menu.









3. From the Service menu select Help desk by pressing  or  and press  a list of numbers should appear.
4. To add a new number press  .
5. Type a Name and press .
6. Type a Number and press .
7. Type a LES acc.code and press .

### Deleting a number

There is only room for ten numbers in the Help desk phone book. If there is no more room for new phone numbers, one will have to be deleted before a new number can be added.

Select a number by pressing  or  and press   to delete the number.

### Edit a number

1. Select a number and press  or  and press   to edit the number.
2. Edit the Name and press .
3. Edit the Number and press .
4. Edit the LES acc.code and press .
5. To exit service menu and return to ready mode press  three times.

### 9.3.3 IMN Config

The IMN Config menu has been divided into the different types of services available:

- mini-M voice
- 9.6 kbps fax (only F77)
- Speech
- 3.1 kHz audio
- 64 kbps UDI (Universal Data Interface)
- 56 kbps UDI
- MPDS
- 128 kbps

In each menu, all IMN's associated with a specific service should be inserted. The IMN's are given by the ISP when commissioning the terminal.

After inserting an IMN number and pressing **OK** the handset will show "ID" and a number. The ISP may also have indicated the corresponding ID's along with the IMN-numbers. If the ID shown by the terminal corresponds with the ID given by the ISP press **OK**. If not, then correct the ID by pressing **C<sup>ins</sup>** for delete, type the correct ID and then press **OK**. If the ISP has not indicated the ID for each IMN number two situations exist:

- If there is not more than one IMN-number pr. service and the IMN list is empty, the ID shown by the terminal will always be correct and thus just press **OK**.
- If there is more than one IMN-number pr. service and the IMN list is empty, the rule is that the first (or upper) IMN on the returned commissioning form will have the lowest ID and each subsequent IMN-number will have an ID which is 1 higher than the predecessor.

## 9.3.4 PIN Codes

### Overview

Access to some of the terminal functionality is restricted by a PIN code. There are two kinds of PIN codes, a Super User and a Service User PIN. Common for both PIN types is that the length must be between 4 and 8 digits long and contains digits between 0 and 9.

If the Super User/Service User PIN code is entered incorrectly 5 times, the PIN becomes blocked.













A blocked Super User PIN, can be unblocked with a PUK code (Normally known to the Super User) or by a Service User.

**The default factory Service User PIN code is '12345678'.**

A blocked Service User PIN can be unblocked with a PUK code or by a Service User.

The Service User PUK code is normally known only to Thrane & Thrane A/S and/or the supplier.









### Changing the Super User Pin

1. From the main menu select Service User by pressing  or  and press .
2. Type the Service User PIN code and press  to enter the Service user menu.
3. From the Service User menu select PIN Codes by pressing  or  and press . Select SU PIN by pressing  or  and press .
4. Press  to type new PIN.
5. Enter new PIN and press . Retype PIN and press .









6. The display should show PIN was OK saved to memory.







## Changing the Service User PIN

1. From the Service User menu select Pin Codes by pressing  or  and press .
2. Select SeU-PIN Chg by pressing  or  and press .
3. Press  to Type New Pin.
4. Enter new PIN and press  Retype Pin and press .
5. The Display should show Pin was OK saved to memory.







## Unlocking a Super User PIN

1. From the Service User menu select PIN Codes by pressing  or  and press .
2. Select SU-Unlock by pressing  or  and press .

### 9.3.5 Dflt. Setting

1. From the Service User menu select Dflt. Setting (Default Setting) by pressing  or  and press .
2. Select Factory Dflt. by pressing  or  and press .
3. press  to confirm that you want to return to Factory default Setting

### 9.3.6 Calibration

1. From the Service User menu select Calibration by pressing  or  and press .
2. Select either IQ-calib or IQ-const by pressing  or  and press .

#### IQ-calib

When you have selected IQ-calib, an IQ calibration is performed. This is only used in special circumstances, as the IQ calibration is done from the factory. If it is activated, it may take about 10 minutes. If it fails you will be told “Failed Try Again” in the handset display for 20 seconds or until you press any key.

While calibrating, “Calibrating Wait...” is written in the handset display. When finished the display says “Done” and the terminal will reset itself.

#### IQ-const

When you select IQ-const, you may read the IQ constants for Modulator and Demodulator. The constants are: Iamp, Qamp, Ioff, Qoff, Phase.

# Hardware Interfaces

## 10.1 Overview

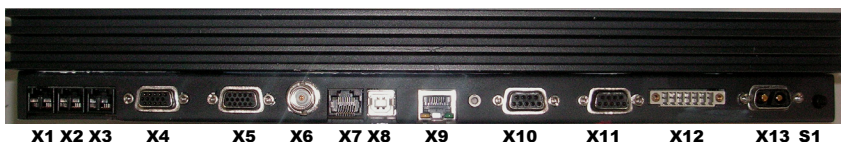

The BDU has the following additional hardware interfaces:

- Analogue 2-wire (phone/fax) RJ11 number 1 (X1)
- Analogue 2-wire (phone/fax) RJ11 number 2 (X2)
- Analogue 2-wire (phone/fax) RJ11 number 3 (X3)
- Handset/Cradle 1 (X4)
- Handset/Cradle 2 (X5)
- Antenna (X6)
- ISDN (Integrated Services Digital Network) (X7)
- USB (Universal Serial Bus) (X8)
- LAN (X9)
- RS-232 (X10)
- NMEA 0183/2000 (X11)\*
- 4 Discreet I/O (X12)
- Power input (X13) - refer to Chapter 8

(\*) For future use - it is currently not supported.

All hardware interfaces are found at the rear of the BDU.

These interfaces can be used for the Inmarsat Fleet services.



## 10.3 Cradle/Handset Interface



Cradle/Handset

The BDU has two 4-wire Cradle/Handset ports with RS-485 data control. The handset can be used to setup the terminal and also can be used to make or receive phone calls. The connector outline and pin assignments are described in the figure and table below. Maximum cable length BDU to Handset/Cradle is 40 meters.

Pin number	Pin function
1	Audio Out Hi
2	Audio Out Lo
3	Audio In Hi
4	Audio In Lo
5	+28 V DC
6	GND
7	SDA
8	SDB
9, 10, 11, 12, 13, 14, 15	-
Shield	GND

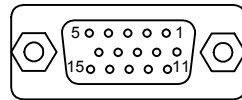

## 10.4 ISDN Interface



↑  
ISDN

This interface can be used for connection of ISDN equipment – data as well as voice/picture based equipment.

The connector outline and pin assignments are described in the figure and table below.

Pin number	Pin function
1	-
2	-
3	RxP
4	TxP
5	TxN
6	RxN
7	-
8	-

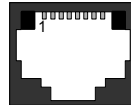

## 10.5 USB Interface

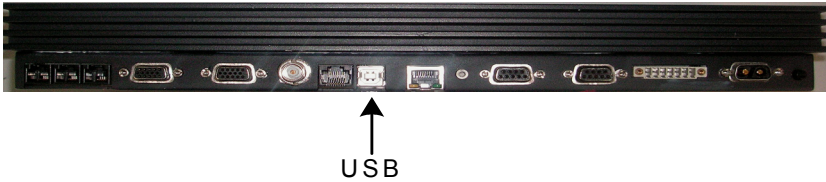

The Universal Serial Bus (USB) - is a popular technology that allows a single universal plug to connect PCs and peripherals of all kinds to each other. The USB replaces all of the different serial and parallel PC connections with one standard plug and port.

The connector outline and pin assignments are described in the figure and table below.

Pin number	Pin function
1	-
2	D-
3	D+
4	-

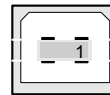

## 10.6 LAN Interface

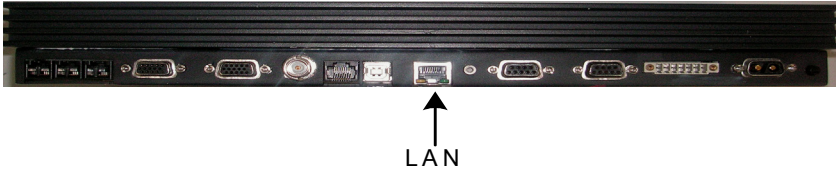

The BDU is equipped with one Ethernet LAN port. The Ethernet port is a standard IEEE 802.3 port and requires a crossed Ethernet cable to a PC.

The LAN port enables the MPDS service.

The connector outline and pin assignments are described in the figure and table below.

Pin number	Pin function
1	TxP
2	TxN
3	RxP
4	Not Used
5	Not Used
6	RxN
7	Not Used
8	Not Used

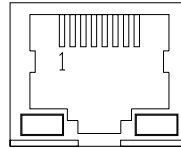



## 10.7 RS-232 Interface



RS 232

The BDU has one RS-232 port. The RS-232 port is a standard 9-pin serial port with a maximum port speed of 115.2 kbps. It can be used for the following service types:

- MPDS service
- Configuration of the terminal via Fleet CP software
- Connection of a IP Router

When installing the configuration program you should connect your PC to the RS-232 interface. The connector outline and pin assignments are described in the figure and table below.

Pin number	Name	Signal
1	DCD	Data Carrier Detect
2	RxD	Received Data
3	TxD	Transmitted Data
4	DTR	Data Terminal Ready
5	GND	Ground
6	DSR	Data Set Ready
7	RTS	Request To Send
8	CTS	Clear To Send
9	RI	Ring Indicator

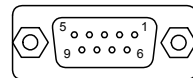

## 10.8 NMEA 0183/2000 Interface



N M E A 0 1 8 3 / 2 0 0 0

This interface is for future use.

## 10.9 Discrete I/O interface



Discrete I/O

The BDU also has a discrete I/O interface containing four input/outputs, of the open collector type. Inputs may be used for F77/GSM operation and outputs for Tx Off, Radio Silence etc.

The connector outline and pin assignments are described in the figure and table below.



Pin number	Connection	Note
1	GND	This group of signals refer to BDU/ship ground
2	+28 V DC/50 mA Out	
3	Common Return	This group of signals are isolated from all other signals.
4	Discrete I/O D	
5	Discrete I/O C	Can be used together with pin 1 and 2 or ship battery (but not at the same time)
6	Discrete I/O B	
7	Discrete I/O A	



# Service and Repair

## 11.1 Introduction

The Thrane & Thrane Fleet systems are designed to operate without preventive routine maintenance.

Although the system is designed and built very service friendly, we strongly recommend that any acting service technician has been trained specifically on the product. Repairs or repair attempts performed by unqualified personnel may limit the warranty.

The warranty on the system is defined and outlined by the Distributor that supplied the system.

For further information on warranty and service, you may also use the Thrane and Thrane home page at <http://www.thrane.com>.

## 11.2 Modules

Repairs inside the BDU is not recommended to be carried out on board, instead the unit should be replaced if defective and repaired at a qualified workshop on shore. With the Configuration module that contains the Inmarsat identity, it is easy to exchange a defective BDU with a working unit.

For exchange of Fleet55 modules you need to remove the top of the radome. For Fleet77 it is not necessary to remove the top of the radome, as all modules can be replaced via the **service hatch**. The modules are easy to replace and no reconfiguration of the system is needed after servicing.

The electronic part of the ADU consists of a number of modules.

The following modules are available as spare parts. See Appendix A.

- HPA Module (High Power Amplifier)
- PSM Module (Power Supply Module)
- ACU Module (Antenna Control Unit)
- SU Module (Sensor Unit)
- ESS Module (End Stop Switch)

## 11.3 Power Supply Module (PSM)

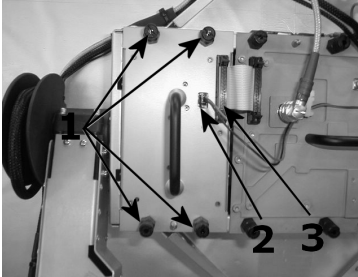

Disconnect plug (2) and (3). Remember to release connector latches on both connectors, do not use the wires to pull out the plugs.

Unscrew the four finger screws marked (1) until the PSM can be removed.

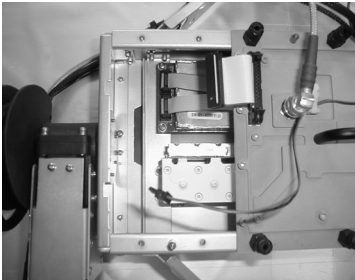

Module refitting is the reverse of the removal procedure.

Observe coding of connector (2).

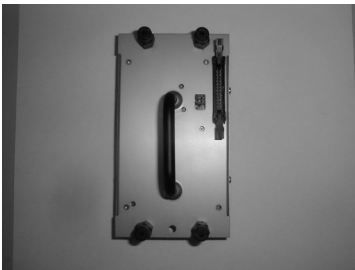

Power supply Module

## 11.4 High Power Amplifier (HPA)

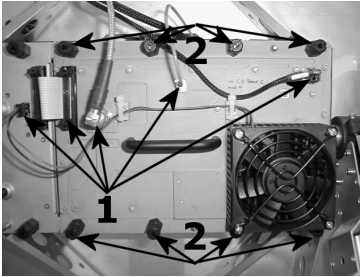

Disconnect the five plugs marked (1). Remember to release connector latches on the connectors, do not use the wires to pull out the plugs.

Unscrew the eight finger screws marked (2) until the HPA can be removed.

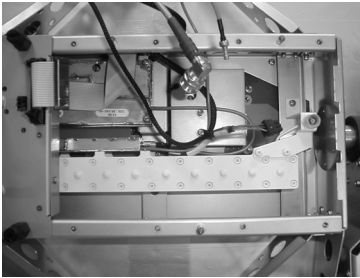

Module refitting is the reverse of the removal procedure.

Observe coding of connectors.

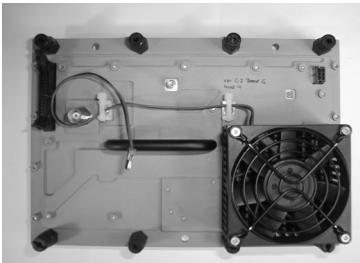

HPA Module



## 11.5 Antenna Control Unit (ACU)

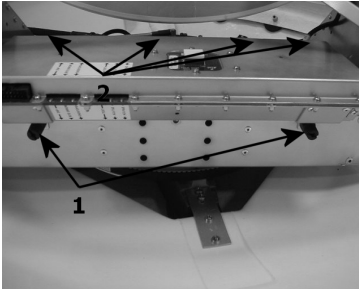

Disconnect the four plugs marked (2). Remember to release connector latches on the connectors, do not use the wires to pull out the plugs.

Unscrew the two finger screws marked (1) until the ACU can be removed.

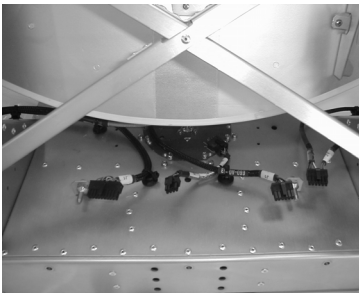

Module refitting is the reverse of the removal procedure.

Observe coding of connectors.

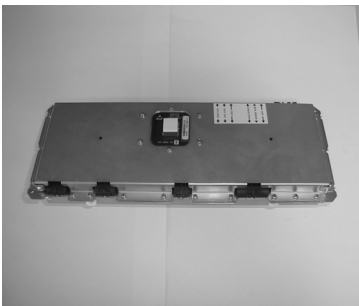

ACU Module

## 11.6 Sensor Unit (SU)

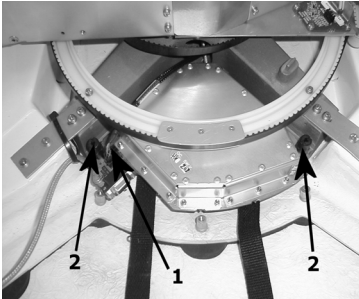

Disconnect the plug marked (1). Remember to release connector latch on the connector, do not use the wires to pull out the plug.

Unscrew the two finger crews marked (2).

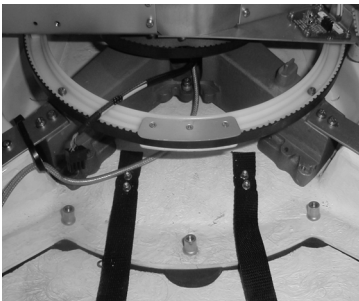

Remove the SU module.

Module refitting is the reverse of the removal procedure.



SU Module

## 11.7 End Stop Switches (ESS)

Disconnect the plugs marked (1,2) the **blue/black** wire.

Disconnect the plugs marked (3,4) the **gray/red** wire, do not use the wires to pull out the plugs.

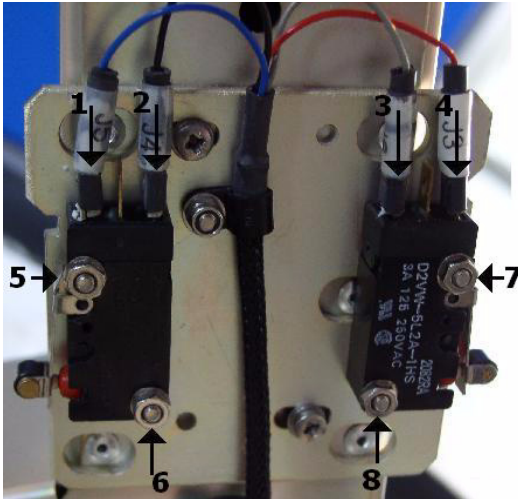

Unscrew the 4 screws marked (5,6,7,8) and replace the switches.

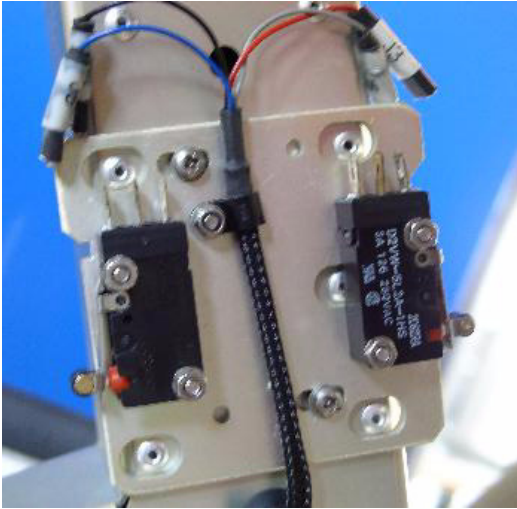

**Note**

When the ESS are reassembled - check that the ESS are being activated by switching the antenna disc from side to side.

When the antenna disc reacts the end stop a “click” should be heard.

# Troubleshooting

## 12.1 Error messages

If the ADU should fail an error message will be sent to the Error log. See User Manual chapter 4 “Operation” and 2.6 “The Handset”.

The error message does not pinpoint the exact location of the unit, which is causing the fault – but it gives an idea of where to start troubleshooting. The error message can be hardware or software related.

If an error message is received - start the troubleshooting by restarting the system.

If other error messages than those shown in the table are received – contact supplier or Thrane & Thrane for Support.

Error message	Possible reason	Action
FEU Status Heat alarm	System error	Restart the system
	Temperature inside the radome exceeds 90°C.	Switch off system and/or open service hatch to ventilate the radome.
	HPA cooler fan failure HPA failure	Replace HPA module
FEU Status Burst alarm	System error	Restart the system
FEU Status Power alarm	HPA fault	Replace HPA module

Error message	Possible reason	Action
Antenna Link down	System error	Restart the system
	Antenna cable disconnected/faulty	Check cable
	PSM module faulty	Replace PSM module
	HPA module faulty	Replace HPA module
	Slip ring faulty	Return the unit for repair
Handset Com Error	No communication between BDU and Handset caused by e.g.: <ul style="list-style-type: none"> <li>• Handset/cradle cable error</li> <li>• BDU error</li> <li>• ADU error</li> </ul>	As this error indicates an error that may be caused by many different reasons, there is an elaborate troubleshooting procedure to follow (cf. below)
1.LO Lock Not Ok	If alarm is persistent the RF-board is defect.	BDU has to be replaced.
2.LO Lock Not Ok	If alarm is persistent the RF-board is defect.	BDU has to be replaced.
3.LO Lock Not Ok	If alarm is persistent the RF-board is defect.	BDU has to be replaced.
ACU Comm. Failure	ACU does not respond to request from BDU.	

Error message	Possible reason	Action
Ant Power Down Failed	BDU is not able to power down the antenna. Is probably caused by a defective transistor (FET) on the power supply PCB.	Replace the BDU Power Supply boards.
Ant Power Up Failed	BDU is not able to power up the antenna. Might be caused by a short circuit in the connecting devices.	
Antenna (ACU) Wrong Type Check Conf.	A wrong antenna type is attached to the BDU (e.g. a F55 antenna to a F77 BDU).	Check/change Antenna Control Unit. Change Config Module to correct type.
Antenna (FEU) Wrong Type Check Conf.	A wrong antenna type is attached to the BDU (e.g. a F55 antenna to a F77 BDU).	Check/change High Power Amplifier. Change Config Module to correct type.
FEU Status power alarm	Checks the HPA output power versus the reference power is not above threshold. If this happens the antenna is reset.	If persisting replace the HPA.
FEU Status reset	HPA has been reset for an unknown reason.	If alarm is persistent the HPA is defect and has to be replaced.

Error message	Possible reason	Action
MIDR Corrupt	MES Identification Record (MIDR) is damaged. Checksum error in record that contains FWD ID and RTN ID.	Please contact Thrane & Thrane Support.
Power has dropped to below 20 V	At some point the supply voltage has dropped to below 20 Volts. If the drop is only for a short while, the alarm might be inactive (no red LED).	If this happens often, please check your external power supply/power source.
SPI CPLD Failed	If alarm is persistent the BDU main board is defect.	BDU has to be replaced.
Vtune alarm <value>	If alarm is persistent the oscillator on the BDU is defect.	BDU has to be replaced.



## 12.2 Handset Com Error troubleshooting procedure

### Step 1: Check alarm log

Check for any active/recent alarms. E.g. low voltage may cause the error and therefore look for any low voltage alarms.

### Step 2: Below deck (BDU, Handset, Cradle) or Above deck (ADU) error?

1. Remove power
2. Disconnect antenna cable
3. Reinstall power
4. Switch on system (disregard “Antenna link down” error”)

Does “Handset Com error” still appear? If yes, it is a below deck error. If no, it is an above deck error.

### Step 3 (if Below deck error): Cradle, Handset or BDU error?

1. Check/replace Handset
2. Check/replace Cradle

If these replacements do not remove the error return defective BDU for repair

### **Step 3 (if Above deck error): ACU, cable or power error?**

1. Switch system off.
2. Connect the antenna cable.
3. Switch system on.
4. In antenna:
  - Check the DSP LED (flash). If no, check 40 V to ADU.
  - Check BITE Error LED (off). If no, replace ACU.
  - Check the RX LED (flash). If no, check com cables.

## Part numbers

### A.1 TT-3086A Sailor Fleet55

Item	Part number
Sailor Fleet55 Antenna (ADU)	TT-3008F
Sailor Fleet55/77 Electronics Unit (BDU)	TT-3038C
Sailor Fleet Cradle without Distress	TT-3622E
Sailor Fleet Control Handset (4 wire)	TT-3620G
Sailor Fleet55 Configuration Module	TT-3038C-002

### A.2 TT-3084A Sailor Fleet77

Item	Part number
Sailor Fleet77 Antenna (ADU)	TT-3008C
Sailor Fleet55/77 Electronics Unit (BDU)	TT-3038C_WMB
Sailor Fleet77 Cradle with Distress	TT-3622B
Sailor Fleet Control Handset (4 wire)	TT-3620G
Sailor Fleet77 Configuration Module	TT-3038C-001

## A.3 Sailor Fleet55/77 Antenna Cables

Item	Part number
50 meter cable, SA07272, N/N	TT37-116689
60 meter cable, SA12272, N/N	TT37-108740-060
0.5 meter pigtail, RG223 N/TNC	TT37-107374-A

**Note**

Antenna cable is not included in the basic package.

## A.4 Sailor Fleet55/77 Accessories

Item	Part number
Sailor Fleet55/77 Power Connector <sup>a</sup>	TT31-202329-104
Sailor Fleet55/77 I/O Connector <sup>a</sup>	TT31-202329-107
Sailor Fleet55/77 User Manual <sup>a</sup>	TT98-116874
Sailor Fleet55/77 Installation Manual <sup>a</sup>	TT98-116875
Sailor Fleet55/77 CDROM (incl. FleetCp) <sup>a</sup>	TT83-117634
Sailor Fleet55/77 Grounding Kit <sup>a</sup>	TT-673084A
Sailor Fleet55/77 Antenna cable 25m	TT37-124298-A

a. Included in the basic TT-3084A / TT-3086A package.

## A.5 Optional Sailor Fleet55 Cradle Cables

Item	Part number
10 m cradle cable <sup>a</sup>	TT37-120468-C
25 m cradle cable	TT37-120469-B
40 m cradle cable	TT37-120470-B

a. Included in the basic TT-3084A / TT-3086A package.

## A.6 Optional Sailor Fleet77 Cradle Cables

Item	Part number
10 m cradle cable <sup>a</sup>	TT37-113607-C
25 m cradle cable	TT37-116543-B
40 m cradle cable	TT37-116544-B

a. Included in the basic TT-3084A / TT-3086A package.

## A.7 Optional Sailor Fleet55/77 Cradles & handsets

Item	Part number
Sailor Fleet Cradle without Distress	TT-3622E
Sailor Fleet77 Cradle with Distress	TT-3622B
Sailor Fleet Control Handset (4 wire)	TT-3620G

## A.8 Sailor Fleet55/77 Spare Part Units

Item	Part number
Sailor Fleet55 Antenna (ADU)	S-403008F
Sailor Fleet77 Antenna (ADU)	S-403008C
Sailor Fleet55/77 Electronics Unit (BDU)	S-403038C

## A.9 Sailor Fleet55/77 ADU Spare Parts

Item	Part number
Sailor Fleet55/77 ADU HPA Pack 2.gen.	S-62-122028
Sailor Fleet55/77 ADU PSM Pack	S-62-116447
Sailor Fleet55/77 ADU ACU Board	S-88-117544
Sailor Fleet55/77 ADU Sensor Unit (SU)	S-88-117545
Sailor Fleet55/77 End stop switch (ESS)	S-88-202908

# F55/77 ADU Technical Specifications

## B.1 F55 Technical Specifications

Item	Specification
Rx Freq. Band	1525.0 - 1559.0 MHz
TX Freq. Band	1626.5 - 1660.5 MHz
Channel Spacing	1.25 kHz
Antenna element	Gain (RX-band, min.): 17.2 dBi Gain (TX-band, typical): 17.5 dBi
G/T	$G/T \geq -7$ dBK
EIRP	Min. EIRP: 5 dBW Max. EIRP: 25 dBW
Return loss	Better than -12 dB/50 $\Omega$

<b>Item</b>	<b>Specification</b>
Cable losses	RF attenuation: max. 10 dB DC resistance (loop): max. 0.75 $\Omega$ Max. Cable length between BDU and ADU: <ul style="list-style-type: none"><li>• RG214: 25 meter</li><li>• SA 07272: 50 meter</li><li>• SA 12272: 60 meter</li></ul>
ADU Input voltage	42 V
ADU Power range, operational	10 W - 150 W
Total ADU Weight	17.6 kg +/- 0.3kg



## B.2 F77 Technical Specifications

Item	Specification
Rx Freq. Band	1525.0 - 1559.0 MHz
TX Freq. Band	1626.5 - 1660.5 MHz
Channel Spacing	1.25 kHz
Antenna element	Gain (RX-band, typical): 19.9 dBi Gain (TX-band, typical): 20.4 dBi
G/T	G/T $\geq$ -4 dBK
EIRP	Min. EIRP: 5 dBW Max. EIRP: 32 dBW
Return loss	Better than -12 dB/50 $\Omega$
Cable losses	RF attenuation: max. 10 dB DC resistance (loop): max. 0.54 $\Omega$ Max. Cable length between BDU and ADU: <ul style="list-style-type: none"> <li>• RG214: 25 meter</li> <li>• SA 07272: 50 meter</li> <li>• SA 12272: 60 meter</li> </ul>
ADU Input voltage	42 V
ADU Power range, operational	12 W - 172 W
Total ADU Weight	27 kg +/- 1 kg

## B.3 F55/F77 Environmental Specifications

Item	Specification
Degree of protection	IP66 according IEC-529
Ambient Temperature	Operational: -25° to +55°C Storage: -40° to +80°C
Vibration	Frequency range: 3-100 Hz Acceleration spectral: 3-13 Hz, +12 dB/octave Density: 13-100 Hz, 0.011 g <sup>2</sup> /Hz Total RMS level: 1.0 g
Icing	Up to 25 mm of ice.
Wind	Normal operation with relative average wind velocity up to 140 knots.
Ship motions: (MAX)	Roll: +/- 30°, period 8 sec., 0.5 g tan. Pitch: +/- 10°, period 6 sec., 0.5 g tan. Yaw: +/- 8°, period 50 sec. Surge: +/- 0.2 g Sway: +/- 0.2 g Heave: +0.5 g Turning rate: +/- 6 deg/s; 1 deg/s <sup>2</sup> Headway: 30 knots
Equipment category	Exposed to the weather - IEC-60945

## B.4 F55 Outline Dimensions

Weight: 17.6 g  $\pm$ 0.3 kg

Wind force: 570 N (140 knots)

Moment at base interface: <250 Nm

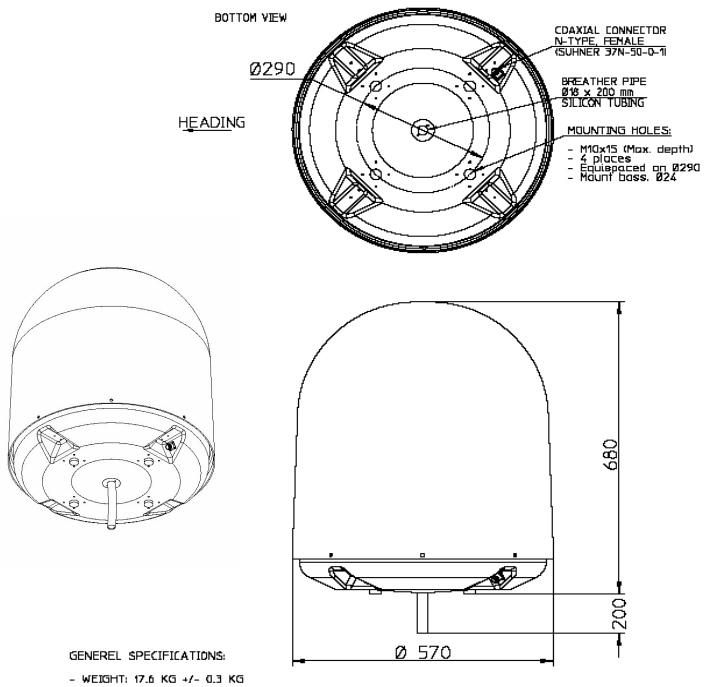

## B.5 F77 Outline Dimensions

Weight: 27 kg  $\pm$ 1 kg

Wind force: 570 N (140 knots)

Moment at base interface: <250 Nm

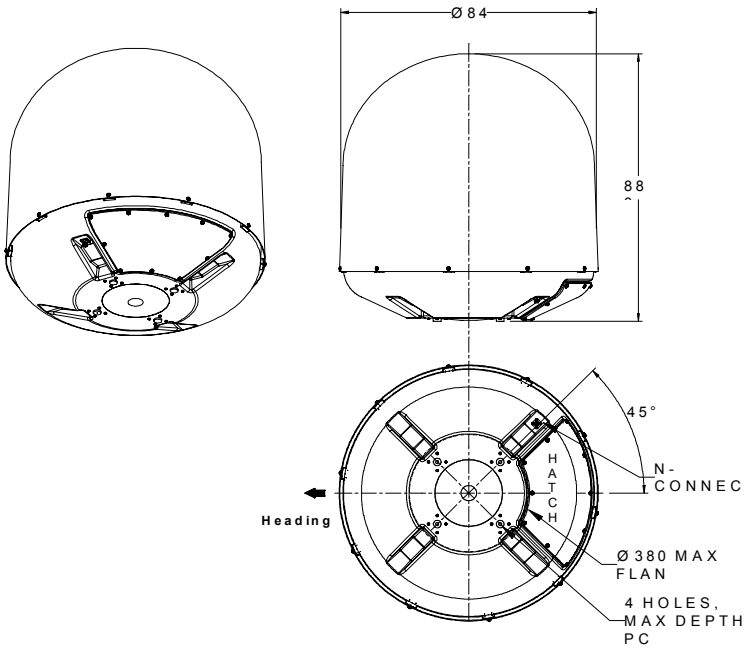

## B.6 Outline Dimensions, Flange

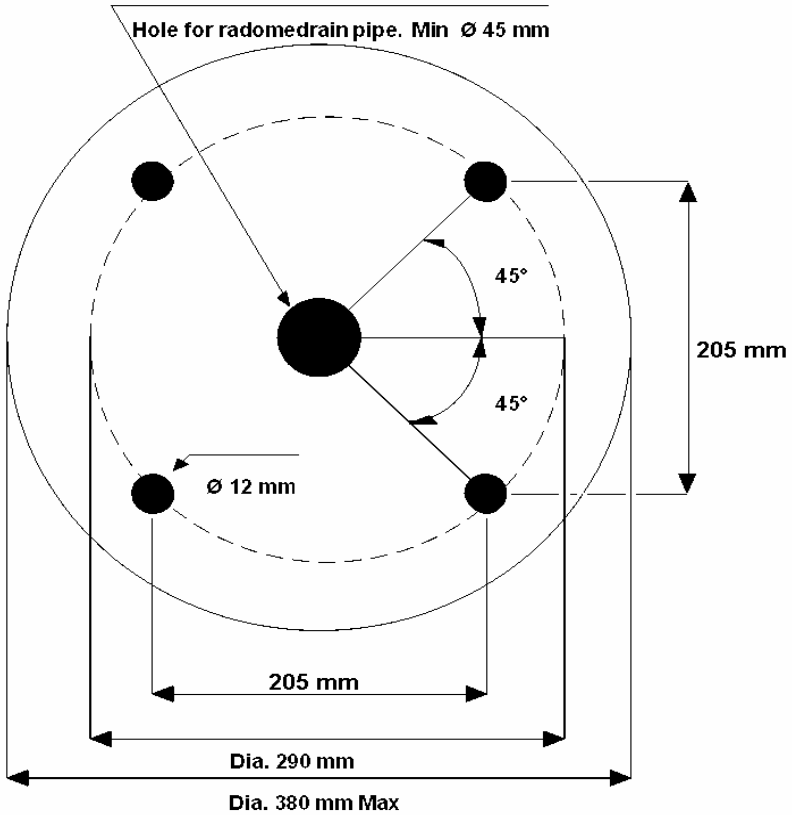

Minimum Recommended Distance to Transmitters.

**Frequency range below 1000 MHz.**

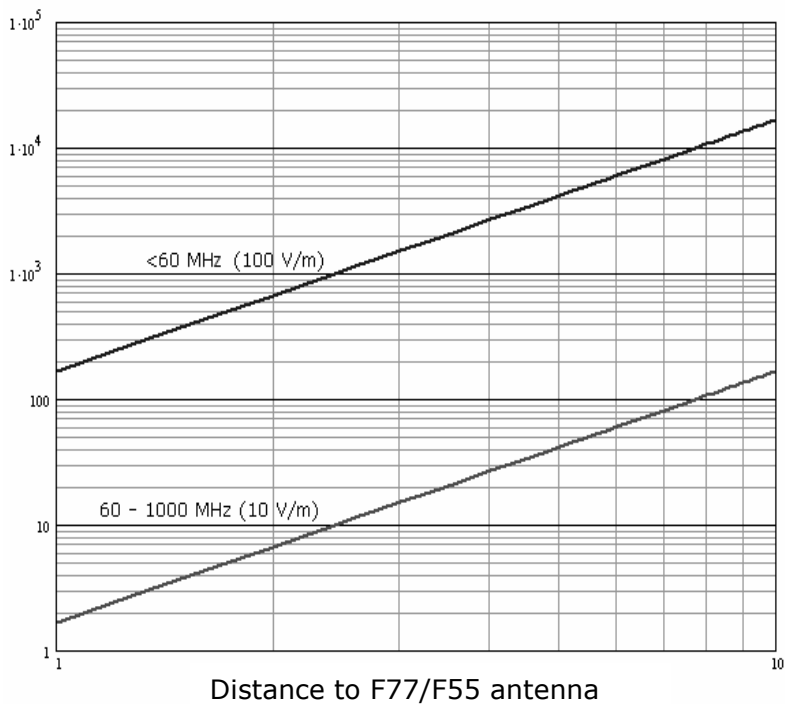

# F55/77 BDU Technical Specifications

## C.1 Technical specifications

Item	Specification
Channel modulation	RX: 5.6 kbps O-QPSK, SCPC (voice) 6 kbps BPSK, TDM 134.4 kbps 16QAM, SCPC (data)  TX: 5.6 kbps O-QPSK, SCPC (voice) 3 kbps BPSK, TDMA 134.4 kbps 16QAM, SCPC (data)
Antenna Connector	TNC-female
Antenna Voltage	+42.5 V DC, +/- 0.5 V DC
2-wire telephone interface; X1, X2, X3	600 $\Omega$ ITU-T Rec. G. 473, standard DTMF telephone, RJ-11 modular jack.  Supported cable length: up to 200 meters
4-wire Handset; X4, X5	Analogue 4 wire interface with RS-485 data.  Nominal supply: 28 V DC, 2.5 W  Supported cable length: up to 40 meters  Connector: DB9 High Density female

<b>Item</b>	<b>Specification</b>
Antenna connector; X6	1525 to 1559 MHz: -70 dBm to -110 dBm 1626.5 to 1660.5 MHz: 2.5 dBm
ISDN interface; X7	Conforms with CCITT I.430, ETSI ETS300012, ANSI T1.605
USB interface; X8	USB 2.0 compliant, Full speed (12 Mbps)
LAN interface; X9	Conforms with IEEE 802.3, 10 Mbps
Data Terminal Interface or Message Terminal; X10	Serial EIA standard RS-232 E, Hayes compatible. Maximum Cable Length: 15 m or max. 2.5 nF cable capacity. Data Rate: up to 115 kbps. Connector: DB9 female.



Item	Specification
<p>X12:</p> <p><b>Output:</b>  DC Power supply  Steady state current  Open circuit resistance  Closed circuit voltage</p> <p><b>Input TT3038C</b>  Input voltage  Input current  High-level input voltage  Low-level input voltage</p> <p><b>Input TT3038C-128-WMB</b>  Input voltage  Input current  High-level input voltage  Low-level input voltage</p>	<p>Conforms with RS410N (open collector)</p> <p>10-52 V  50 mA Max.  100 K<math>\Omega</math> Min.  2 V Max.</p> <p>7.5 V Max.  12.5 mA Max.  3.5 V Min.  1.0 V Max.</p> <p>32 V Max.  10 mA Max.  4.5 V Min.  2.0 V Max.</p>
<p>Power Input; X13</p>	<p>Nominal 24 VDC (-10%/+30%)</p> <p>Typical 10 A during call</p> <p>Maximum 16 A@24 V 15 ms (start up)</p>
<p>Ambient temperature:</p>	<p>Operational: -15° to +55°C</p> <p>Storage: -40° to +80°C</p>
<p>Relative Humidity</p>	<p>95% non-condensing at +40°C</p>
<p>Equipment category</p>	<p>Protected from the weather - IEC-60945</p>

## C.2 Outline dimensions

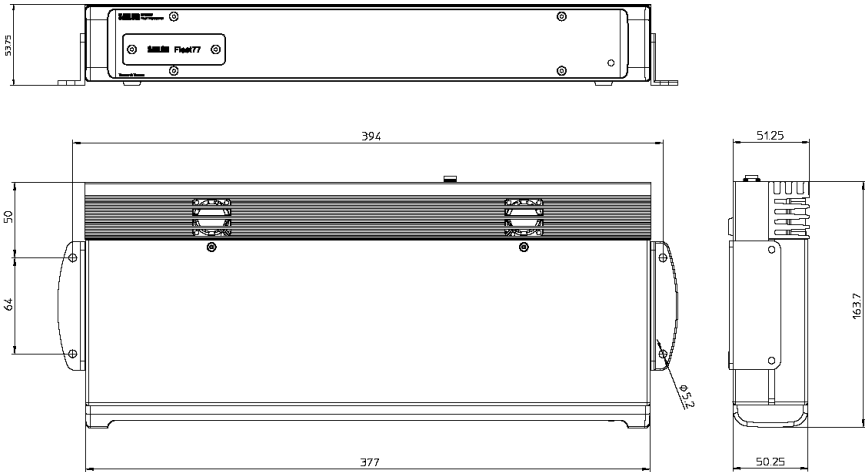

Weight: 2.6 kg.

Dimensions are in mm.

## C.3 Measuring the Ship Source Impedance

Select a power outlet from the ship 24 V DC system, and measure the source impedance of the ship installation as described below.

Measure the voltage without load (R.var disconnected).

Set the current to e.g. 1 A by adjusting R.var - and measure the corresponding voltage change.

Example:

1 A and 50 mV. Source impedance:  $50 \text{ mV} / 1 \text{ Amp} = 50 \text{ m}\Omega$ .

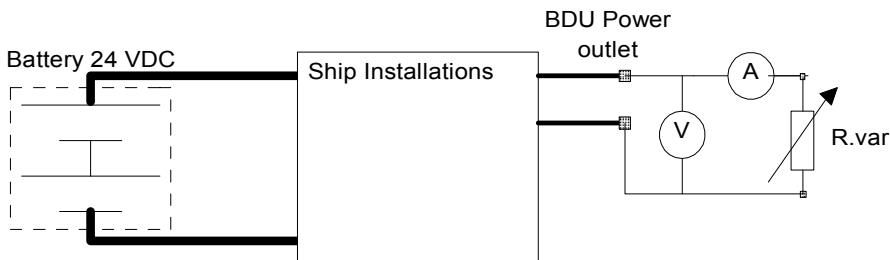



# Distress Cradle Technical Specifications

## D.1 Technical specifications

Item	Specification
Interface to BDU	Connector type: DB9HD male Connector type: M80-8881005 (female on cable), M80-8671022 (male to PCB) Audio RX, 2 wire balanced, 600 $\Omega$ Audio TX, 2 wire balanced, 600 $\Omega$ Max. 40 m Cable
Interface to Handset	Connector type: RJ45 10-pole female
Distress Audible Alarm	75-85 dBA @ 1 m
Power consumption	Max. 90 mA @ 28 V supply voltage
Compass safety distance	1.25 m
Degree of protection	IP40 according IEC-529
Ambient temperature:	Operational: -15° to +55°C Storage: -40° to +80°C
Relative Humidity	95% non-condensing at +40°C

<b>Item</b>	<b>Specification</b>
Dimensions (H x W x D)	100 mm x 145 mm x 42 mm
Weight	0.25 kg excl. cable
Equipment category	Protected from the weather - IEC-60945

## D.2 Outline Dimensions

Dimensions are in mm.

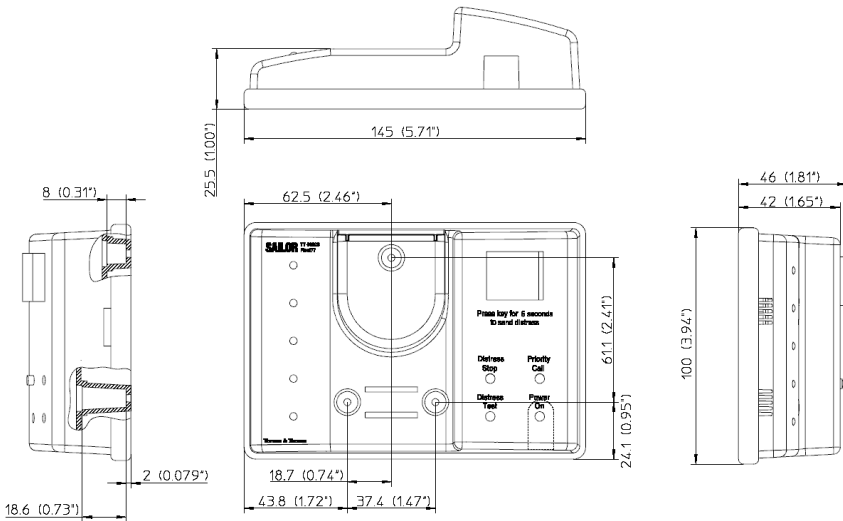





# Passive Cradle Technical Specifications

## E.1 Technical Specifications

Item	Specification
Interface to BDU	Connector type: DB9HD male Connector type: M80-8881005 (female on cable), M80-8671022 (male to PCB) Audio RX, 2 wire balanced, 600 $\Omega$ Audio TX, 2 wire balanced, 600 $\Omega$ Max. 40 m Cable
Interface to Handset	Connector type: RJ45 10-pole female
Power consumption	Max. 75 mA @ 28 V supply voltage
Compass safety distance	125 cm.
Degree of protection	IP40 according IEC-529
Ambient temperature	Operational: -15° to +55°C Storage: -40° to +80°C
Relative Humidity	95% non-condensing at +40°C
Dimensions (H x W x D)	139 mm x 61 mm x 28 mm
Weight	0.18 kg excl. cable

## E.2 Outline Dimensions

Dimension are in mm.

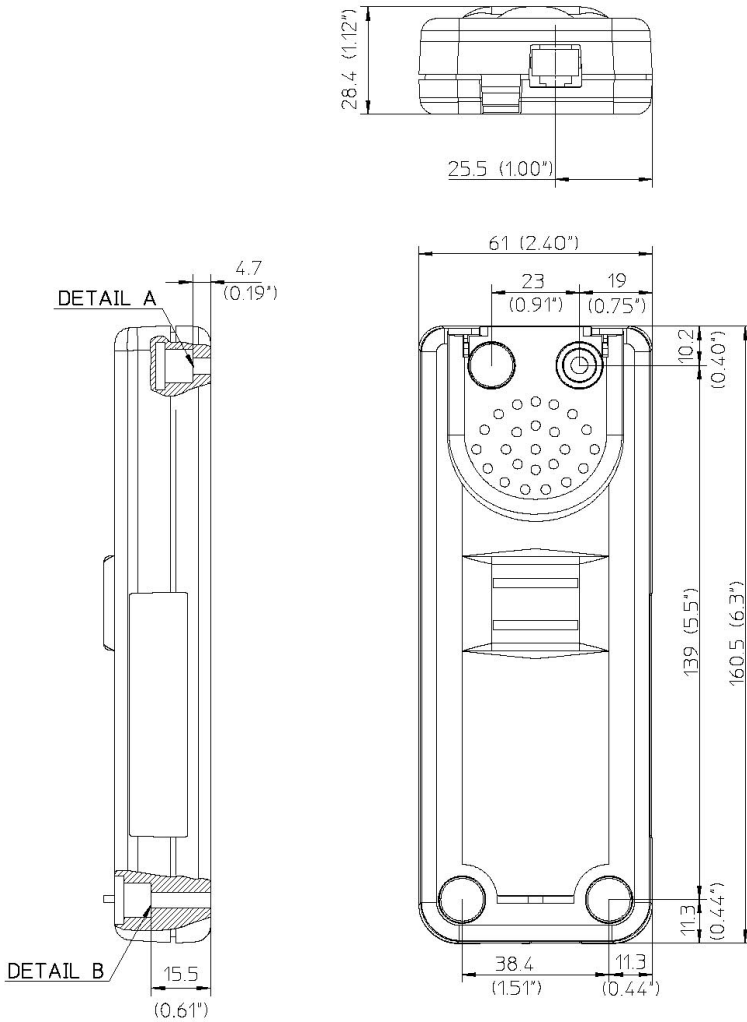





# Handset Technical Specifications

## F.1 Technical Specifications

Item	Specification
Display	2 * 12 Alpha, plus additional symbols. Background light.
Keypad	4 * 3 Numeric Keypad 3 * 3 Function Keypad
Volume Control	Att.range > 20 dB
Power consumption	100 mA @ 5 V supply voltage
Compass safety distance	125 cm
Degree of protection	IP40 according IEC-529
Interface	Connector type: RJ45 10-pole
Ambient temperature	Operational: -15° to +55°C Storage: -40° to +80°C
Relative Humidity	95% non-condensing at +40°C
Dimensions (H x W x D)	200 x 52 x 33 mm
Weight	0.24 kg
Equipment category	Protected from the weather - IEC-60945

## F.2 Outline Dimensions

Dimension are in mm.

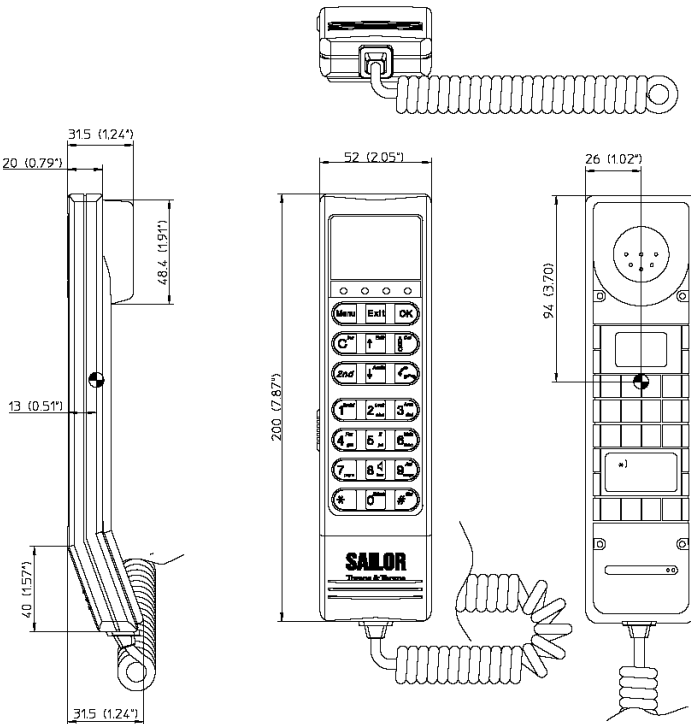

# *Grounding and RF protection*

## **G.1 Why is grounding required?**

### **G.1.1 Reasons for grounding**

Grounding of the Fleet77/55system is required for three reasons:

- Safety: Lightning protection of persons and equipment
- Protection: ESD (ElectroStatic Discharge) protection of equipment
- Performance: Interference free communication between BDU and ADU

### **G.1.2 Safety**

First of all grounding of the Fleet77/55system is required for safety reasons. In the event of a lightning strike at the ADU a proper grounding of the system will provide a low resistance path to divert the strike discharge to seawater.

### **G.1.3 Protection**

Secondly the ESD protection circuits in the BDU rely on a proper grounding of the system in order to work properly. Otherwise sensitive circuits within the BDU might be damaged due to ESD when handling the equipment.

### **G.1.4 Performance**

Finally a proper grounding of the system will enhance RF immunity thus ensuring interference free modem communication between BDU and ADU. This modem communication is essential for the performance of the Fleet77/55system.

## G.2 General about marine DC system

### G.2.1 Wiring systems

There are two basic wiring topologies used for marine DC system grounding: **Two-Wire Return System** and **One Pole Grounded Return System**.

### G.2.2 Two-wire Return System

This configuration implies that no part of the circuit, in particular the battery negative, is connected to any ground potential or equipment. The system is totally isolated and includes engine sensors, starter motors etc. This arrangement is preferred for steel and aluminum vessels.

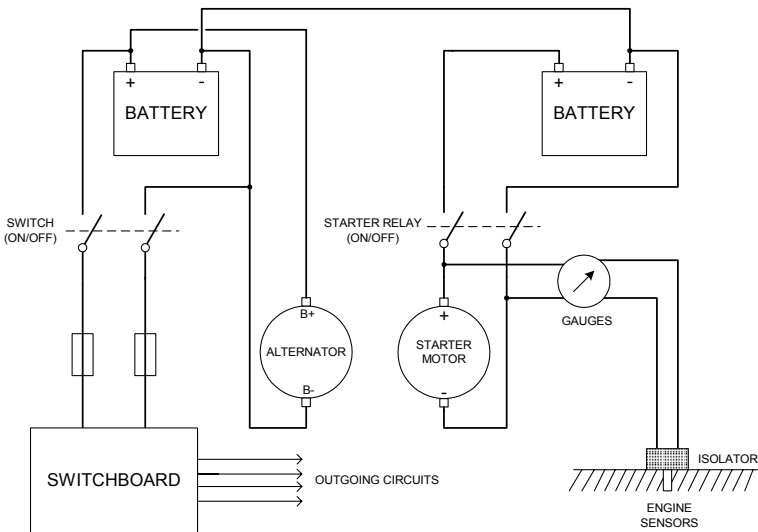



## G.2.3 One Pole Grounded Return System

This configuration implies that the battery negative is bonded to a ground potential, typically at the engine negative terminal. This is done in order to polarize the DC electrical system.

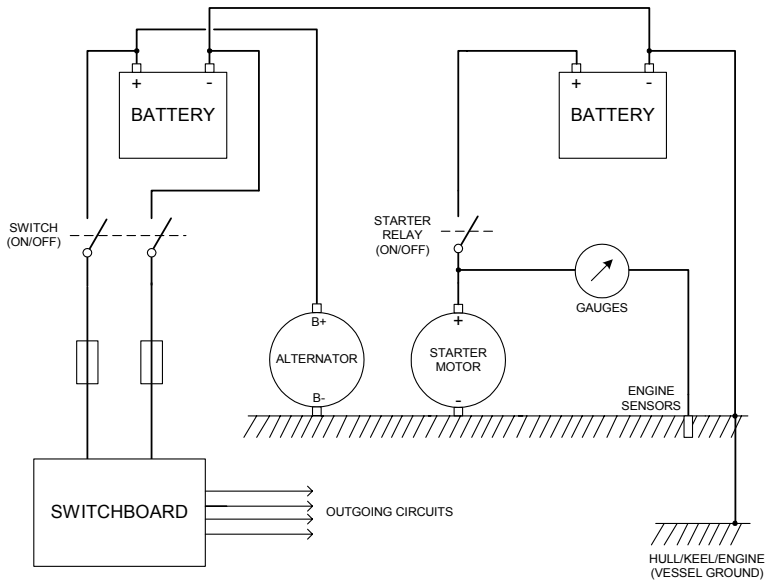

### Note

This arrangement is not suitable for steel and aluminum vessels as this might cause electrolytic corrosion of the hull.

## **G.3 General about marine grounding**

### **G.3.1 Ground terms**

Great confusion exists about the different ground terms used when dealing with marine electrical installations. A distinction between the various terms is listed below for reference.

### **G.3.2 DC Negative**

Actually not a ground but a current carrying conductor which carries the same current that flows in the positive conductor. The DC Negative may be electrically connected to seawater (at one point only, via the engine negative terminal though the shaft and the propeller) or left completely floating.

### **G.3.3 Lightning Ground**

Ground potential immersed in seawater. Provides a path to ground lightning strike energy. Please note that this is not a functional part of any other electrical system.

### **G.3.4 Corrosion System Ground**

Bonding arrangement that ensures equal electrical potential for all dissimilar underwater metal parts and provides galvanic protection by means of sacrificial anodes.

### **G.3.5 AC Ground (Protective Earth)**

Ground potential immersed in seawater (typically the hull for steel and aluminum vessels). Serves as safety ground (protective earth) thus preventing shocks or electrocution in the event of a fault situation.

### **G.3.6 RF Ground (Capacitive)**

Underwater ground potential that is capacitive coupled to seawater ground. Typically numerous pieces of bonded underwater metal parts such as keel (isolated) water tank, engine block etc. will act as a capacitive RF ground (that is; no DC connection to seawater). Often referred to as “counterpoise” for the SSB/HF aerial system.

### **G.3.7 RF Ground (Electrical)**

Underwater ground potential that is electrically coupled to seawater ground by means of a separate ground plate (e.g. Dynaplate). Also referred to as “counterpoise” for the SSB/HF aerial system.

## G.4 Grounding Recommendations

### G.4.1 Grounding the BDU

The BDU must be grounded to the ship/hull by means of the Antenna Pigtail Cable and the Grounding Kit (accessories, TT-403088A-930). Further, the BDU must be grounded at its grounding stud in order to ensure a proper grounding if the pigtail is disconnected.

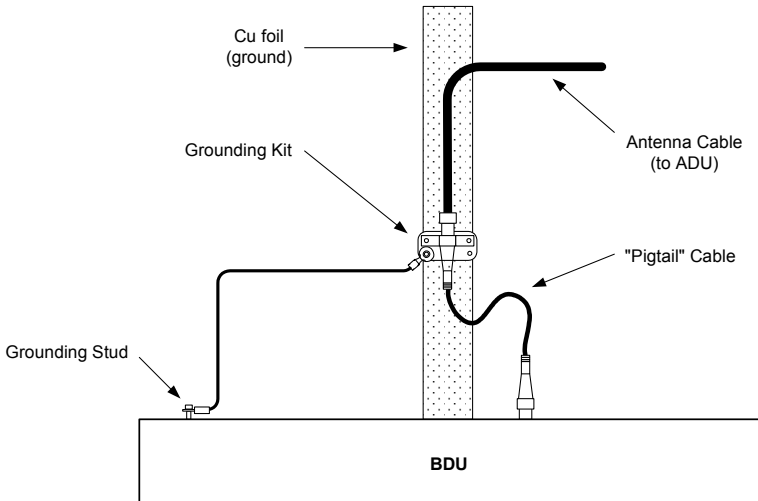

## G.4.2 Grounding the ADU

The ADU must be grounded to the ship/hull via **at least** one of its mounting bolts. Make sure to remove painting, dirt, grease etc. at the mounting holes in order to make good electrical contact to the hull. Use serrated washers when securing the mounting bolts and seal the joint with protective coating to avoid corrosion.

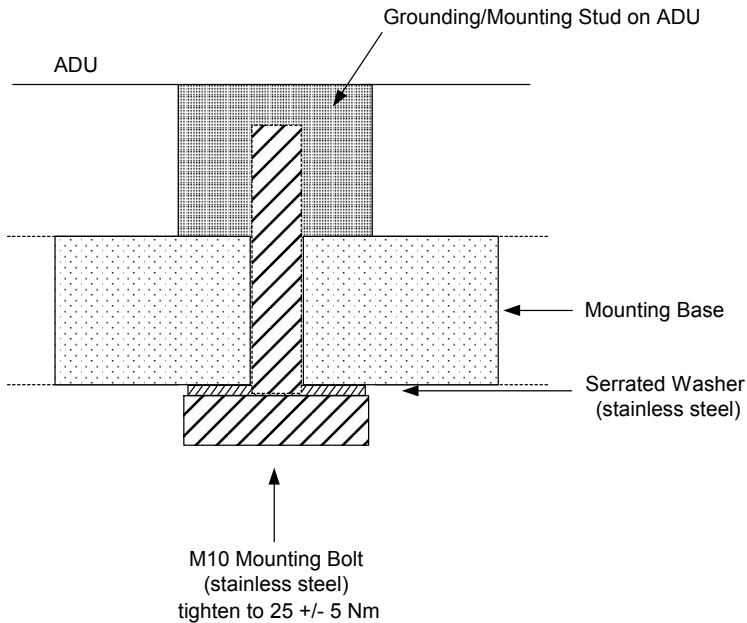

It is always recommended to establish the shortest grounding path as possible e.g. on steel hulls the ADU should be grounded directly to the hull<sup>1</sup>. However, due to the fact that this is not possible on e.g. fiberglass hulls (nor is it preferable on aluminum hulls) a number of alternative grounding methods are suggested in the following paragraphs.

1. Please note that the ADU ground connection is made at the same electrical ground potential as the BDU.

## G.5 Alternative grounding for steel hulls

The following guidelines assume a two-wire, isolated grounding arrangement; that is no part of the circuit, in particular the battery negative, is connected to any ground potential or equipment.

### G.5.1 Grounding the BDU

The BDU must be grounded to the ship by means of the Antenna Pigtail Cable and the Grounding Kit (accessories, TT-403088A-930). Further, the BDU must be grounded at its grounding stud in order to ensure a proper grounding if the pigtail is disconnected.

The ground connection can be established either at the hull (recommended) or at a dedicated RF ground if available (alternative). However, bear in mind that the ADU ground connection is to be made at the **same electrical ground potential as the BDU** (see *Grounding the ADU*).

The BDU provides galvanic isolation (as required) from its input power terminals to the chassis/grounding stud. This way the isolated grounding arrangement is maintained.

### G.5.2 Grounding the ADU

BDU grounded at the hull (recommended):

In this case the ADU must be grounded to the ship via one (or more) of its mounting bolts. Make sure to remove painting, dirt, grease etc. at the mounting holes in order to make good electrical contact to the hull. Use serrated washers when securing the mounting bolts and seal the joint with protective coating to avoid corrosion.

**BDU grounded at a dedicated RF ground (alternative):**

In this case the ADU must be grounded by means of a separate ground cable. The ground cable must be routed parallel and in close proximity to the shielded coax cable hence connecting the ADU to the BDU Grounding Kit. A tinned heavy gauge wire (min. 6 mm<sup>2</sup>) can be used for this purpose - see page 119.

**Note**

The ADU must be electrically isolated at its mounting bolts by means of shoulder bushes and washers thus ensuring the isolated RF ground - see page 123.

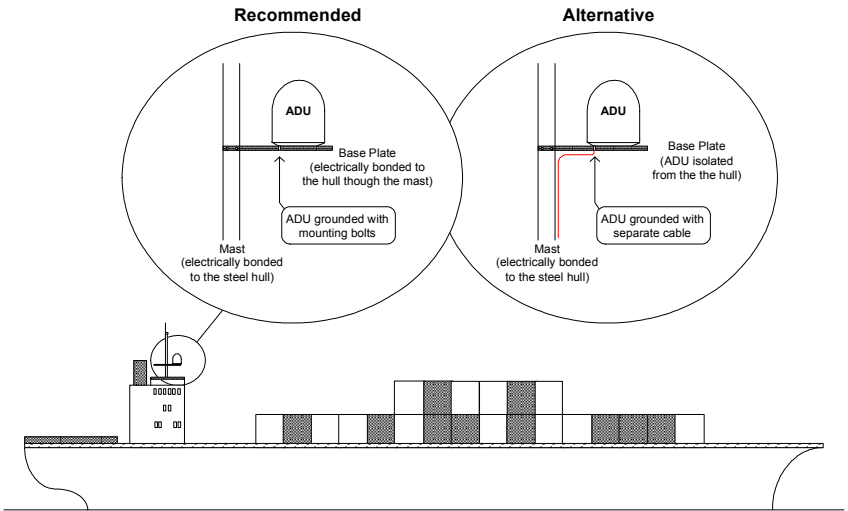

## G.6 Alternative grounding for aluminum hulls

The following guidelines assume a two-wire, isolated grounding arrangement; that is no part of the circuit, in particular the battery negative, is connected to any ground potential or equipment.

### G.6.1 Grounding the BDU

The BDU must be grounded by means of the Antenna Pigtail Cable and the Grounding Kit (accessories, TT-403088A-930). Further, the BDU must be grounded at its grounding stud in order to ensure a proper grounding if the pigtail is disconnected.

The ground connection must be established at a dedicated RF ground (either capacitive or electrical coupled). Bear in mind that the ADU ground connection is to be made at the **same electrical ground potential** as the BDU (see *Grounding the ADU*).

The BDU provides galvanic isolation (as required) from its input power terminals to the chassis/grounding stud. This way the isolated grounding arrangement is maintained.

### G.6.2 Grounding the ADU

If the mounting base of the antenna is electrically connected to the hull (or any other ground potential than the BDU), the ADU must be isolated at its mounting bolts by means of shoulder bushes and washers - see page 123. This is done in order to prevent DC currents flowing in the hull thus causing electrolytic corrosion.

However, a ground connection must be established via one of the mounting bolts using a separate ground cable. The ground cable must be routed parallel and in close proximity to the shielded coax cable hence connecting the ADU to the BDU Grounding Kit. A tinned heavy gauge wire (min. 6 mm<sup>2</sup>) can be used for this purpose - see page 115.



Alternative grounding for aluminum hulls

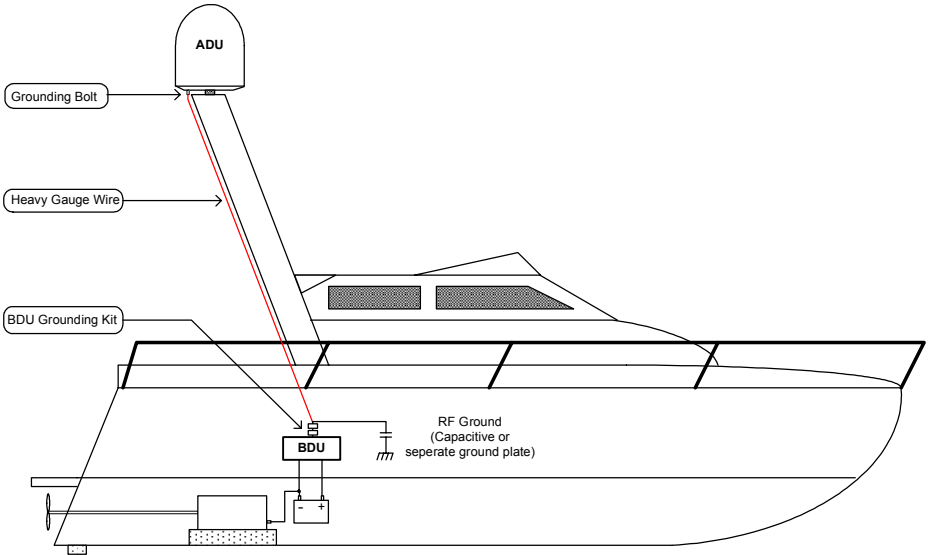

## G.7 Alternative grounding for fiberglass hulls

### G.7.1 Grounding the BDU

The BDU must be grounded by means of the Antenna Pigtail Cable and the Grounding Kit (accessories, TT-403088A-930). Further, the BDU must be grounded at its grounding stud in order to ensure a proper grounding if the pigtail is disconnected.

The ground connection must be established at a dedicated RF ground (either capacitive or electrical coupled). Bear in mind that the ADU ground connection is to be made at the **same electrical ground potential** as the BDU (see *Grounding the ADU*).

### G.7.2 Grounding the ADU

If the mounting base of the antenna is electrically connected to any other ground potential than the BDU (e.g. Lightning Ground), the ADU must be isolated at its mounting bolts by means of shoulder bushes and washers - see page 123.

However, a ground connection must be established via one of the mounting bolts using a separate ground cable. The ground cable must be routed parallel and in close proximity to the shielded coax cable hence connecting the ADU to the BDU Grounding Kit. A tinned heavy gauge wire (min. 6 mm<sup>2</sup>) can be used for this purpose - see page 117.

Alternative grounding for fiberglass hulls

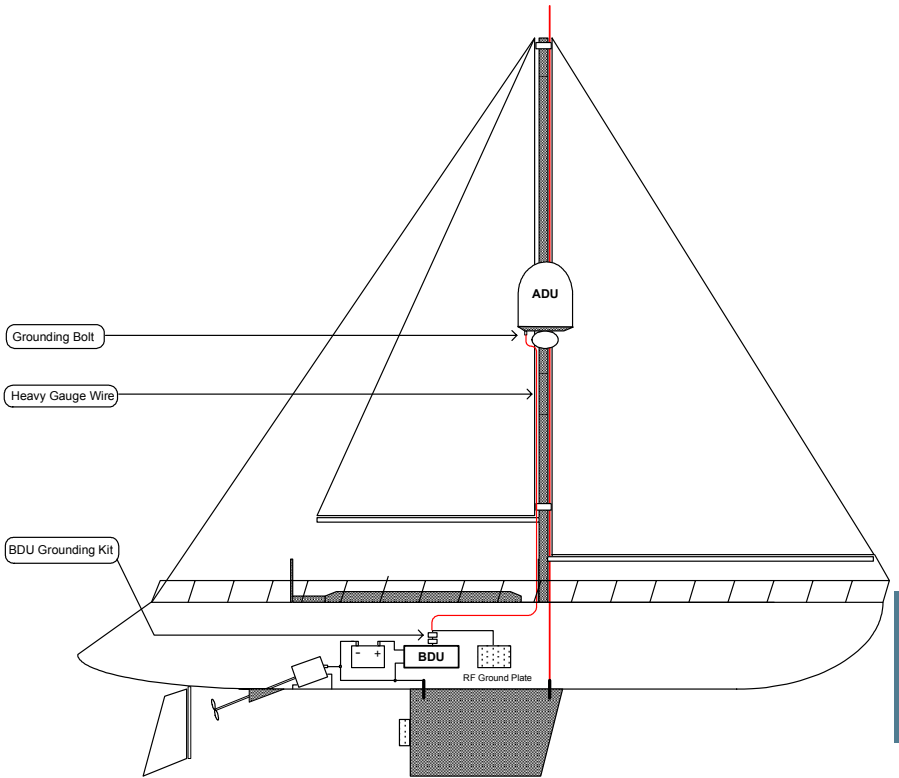

## G.8 Alternative grounding for timber hulls

### G.8.1 Grounding the BDU

The BDU must be grounded by means of the Antenna Pigtail Cable and the Grounding Kit (accessories, TT-403088A-930). Further, the BDU must be grounded at its grounding stud in order to ensure a proper grounding if the pigtail is disconnected.

The ground connection must be established at a dedicated RF ground (either capacitive or electrical coupled). Bear in mind that the ADU ground connection is to be made at the **same electrical ground potential** as the BDU (see *Grounding the ADU*).

### G.8.2 Grounding the ADU

If the mounting base of the antenna is electrically connected to any other ground potential than the BDU (e.g. Lightning Ground), the ADU must be isolated at its mounting bolts by means of shoulder bushes and washers - see page 123.

However, a ground connection must be established via one of the mounting bolts using a separate ground cable. The ground cable must be routed parallel and in close proximity to the shielded coax cable hence connecting the ADU to the BDU Grounding Kit. A tinned heavy gauge wire (min. 6 mm<sup>2</sup>) can be used for this purpose - see page 119.

Alternative grounding for timber hulls

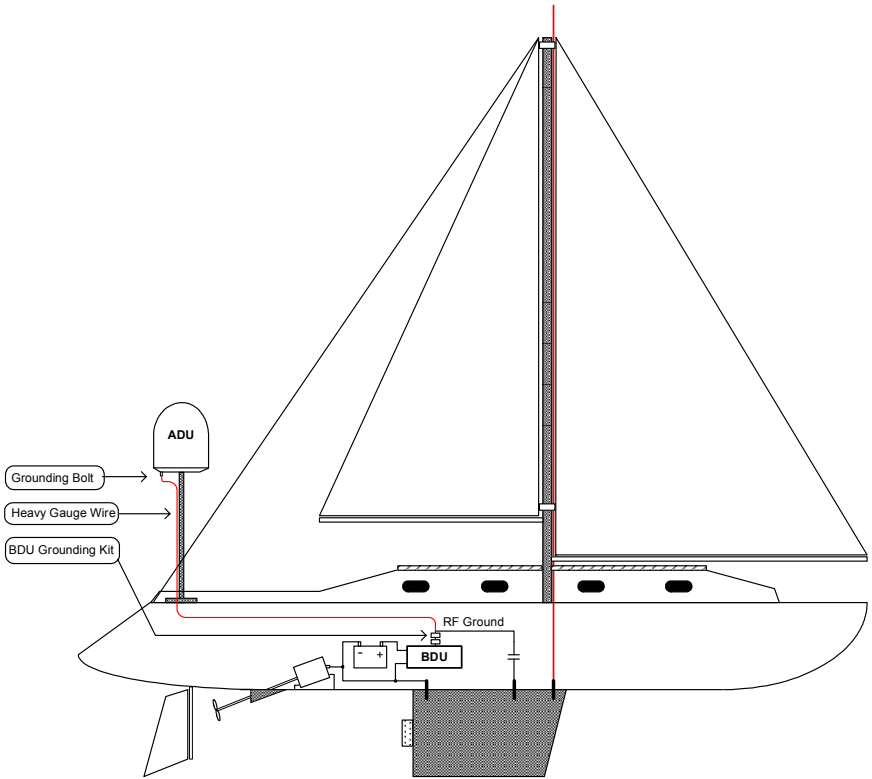

## G.9 Separate Ground Cable

### G.9.1 Ground Cable - Construction

When dealing with electrical installations in a marine environment, all wiring must be done with double insulated, tinned, high quality and if exposed also UV resistant cables. This shall also apply to the separate ground cable mentioned in the previous paragraphs.

The ground cable is constructed using an appropriate cable with a cross section area of at least  $6 \text{ mm}^2$  (AWG10) and terminated with insulated ring crimp terminals – see illustration below. The crimp terminals must be a marine approved type e.g. the DuraSeal series from Raychem.

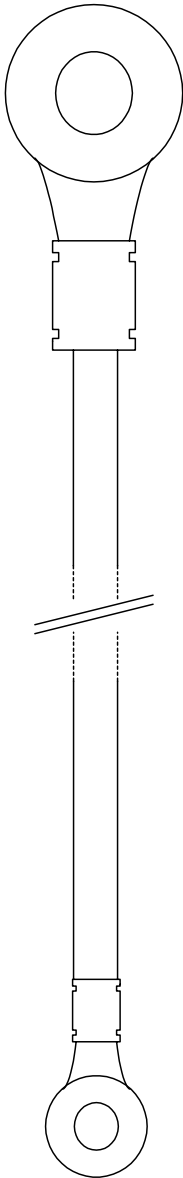

**ADU:**  
M10 Insulated Ring Terminal  
(Raychem, DuraSeal Series )

**BDU:**  
M4 Insulated Ring Terminal  
(Raychem, DuraSeal Series )

## G.9.2 Ground Cable - Connection

The ground cable must be mounted parallel (and in close proximity) to the shielded coax cable thus minimizing ground loop problems. If possible, route the coax cable and the ground cable in metal conduits bonded to the hull or within a mast (depending on the actual installation).

The ground cable must be connected at one of the mounting/grounding bolts on the ADU. Use bolts and washers of stainless steel and seal the joint with protective coating to avoid corrosion. If the ADU is to be isolated from the mounting base, shoulder bushes and washers must be used - see page 123.

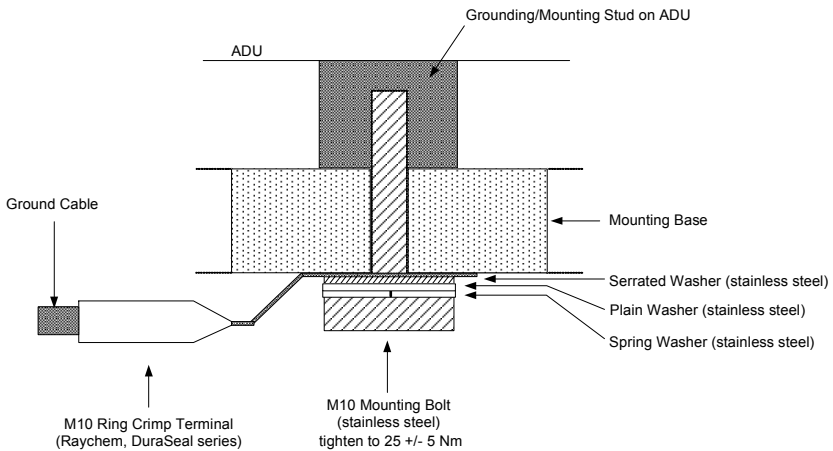

At the other end the connection of the ground cable is straightforward and must be made at the BDU Grounding Kit.



### G.9.3 Isolation of ADU from the mounting base

In cases where the ADU is to be isolated from the mounting base, shoulder bushes and washers (accessories) must be used as illustrated below. Please note that the isolation has to be implemented on all four mounting bolts (including the bolt securing the ground cable).

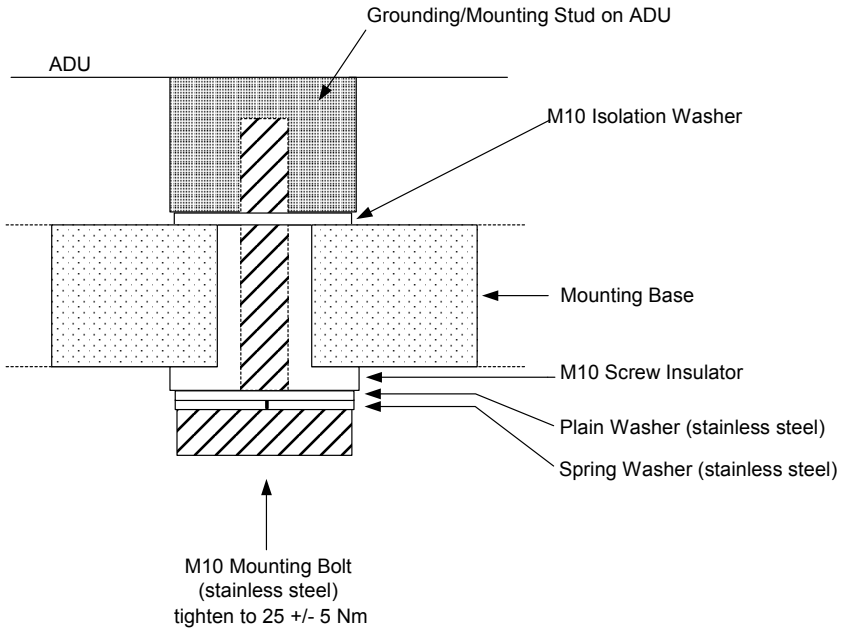

The ground cable must be connected at one of the mounting/grounding bolts on the ADU as illustrated below. Remember to seal the joint with protective coating to avoid corrosion.

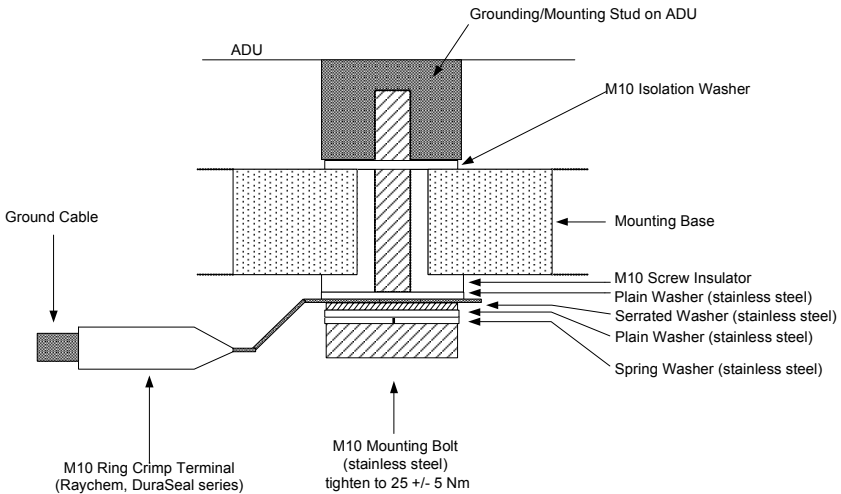

## G.10 RF interference

Interference induced from nearby RF transmitters might cause system failures and in extreme cases permanent damage to the Fleet77/55 equipment. If problems with interference from HF transmitters are encountered <sup>2</sup>, it is advisable to mount ferrite clamps on the coax cable in order to provide suppression of induced RF. The ferrites will have no effect on the differential-mode signals but increases the impedance in relation to common-mode RFI.

### G.10.1 Recommendations

1-5 pcs. hinged clamp cores (e.g. the RFC or SFC series from Kitagawa) mounted on the antenna cable nearby the ADU.

---

2. Typically this will result in the handset error message: "ACU comm. error".

## G.11 Electrostatic Discharge

In addition to the RFI attenuation, mounting ferrite clamps on the antenna cable will also slow the fast rate-of-rise of an electrostatic discharge current pulse. This might be an issue during installation (antenna cable disconnected) where different electrical potentials have had the chance to build-up between the BDU and ADU.

### G.11.1 Recommendations:

1-5 pcs. hinged clamp cores (e.g. the RFC or SFC series from Kitagawa) mounted on the antenna cable nearby the ADU

## A

ACU                      Antenna Control Unit

ADU                      Above Deck Unit

## B

BDU                      Below Deck Unit.

BITE                      Built-In Test Equipment. A BITE error is a hardware error detected by the automatic error detection system.

## D

DTMF                      Dual Tone Multi Frequency. The keypad signaling technology that generates two distinct tones when each key is pressed. This system allows navigation of voice menus and other advanced calling services. All wireless phones use DTMF dialing.

## E

EIRP                      Effective Isotropically-Radiated Power. The amount of power that would have to be emitted by an isotropic antenna (that evenly distributes power in all directions) to produce the peak power density observed in the direction of maximum antenna gain.

ESD                      ElectroStatic Discharge

ESS                      End Stop Switch

## G

GMDSS                      Global Maritime Distress and Safety System

**GPS** Global Positioning System. A system of satellites, computers, and receivers that is able to determine the latitude and longitude of a receiver on Earth by calculating the time difference for signals from different satellites to reach the receiver.

**GSM** Global System for Mobile communication. A European digital standard for mobile or cellular telephony.

## H

**HPA** High Power Amplifier

## I

**IMO** International Maritime Organization

**IMSO** International Maritime Satellite Organisation

**ISDN** Integrated Services Digital Network. An international communications standard for sending voice, video, and data over digital telephone lines or normal telephone wires. ISDN supports data transfer rates of 64 kbps.

## L

**LAN** Local Area Network. A system that links together electronic office equipment such as computers and word processors, and forms a network within an office or building.

**LED** Light Emitting Diode

**LES** Land Earth Station. The LES is located at the "other" end of the MES's satellite link. The LES connects to the local telephone networks and manages calls to and from the MES.

**M**

MES	Mobile Earth Station. Inmarsat name for mobile satellite terminals.
MIDR	MES IDentification Record
MPDS	Mobile Packet Data Service
MSI	Maritime Safety Information

**N**

NMEA	National Marine Electronics Association. NMEA 0183 is a combined electrical and data specification for communication between marine electronics and also, more generally, GPS receivers.
------	--

**P**

PCB	Printed Circuit Board
PIN	Personal Identification Number
PSM	Power Supply Module
PUK	PIN Unblocking Key. An eight-digit code used to unblock a SIM card after three incorrect PINs have been entered. The PUK code is supplied with the SIM card.

**R**

RF	Radio Frequency
RFI	Radio Frequency Interference. A non-desired radio signal which creates noise or dropouts in the wireless system or noise in a sound system.

## S

SCPC	Single Channel Per Carrier. A narrowband transmission mode used to relay a single channel of audio, video and data information over a single carrier.
SOLAS	Safety Of Life At Sea
SU PIN	Super User PIN
SU	Sensor Unit

## T

TDMA	Time Division Multiple Access. A technique for multiplexing multiple users onto a single channel on a single carrier by splitting the carrier into time slots and allocating these on an a-needed basis.
TNID	Terrestrial Network ID

## U

UDI	Universal Data Interface or Unrestricted Digital Information. A transparent 64 kbps data channel.
USB	Universal Serial Bus. An interface standard for communication between a computer and external peripherals over an inexpensive cable using biserial transmission. Mostly used with keyboards, mice, monitors and printers.



**A**

- Above Deck Unit
  - cables, 20
  - grounding, 19
  - grounding recommendations, 111
  - installing, 19
  - isolation from mounting base, 123
  - short description, 2
  - spare parts, 64
  - specifications, 81
- alarms, 71
- aluminum hulls
  - grounding, 114
- analogue 2-wire Interface, 54
- antenna
  - interference, 9
  - mast design, 14
  - obstructions, 7
  - radiation, 8
- Antenna Control Unit
  - replacing, 67

**B**

- Below Deck Unit
  - dimensions, 92
  - grounding, 24
  - grounding recommendations, 110
  - installation location, 23
  - installing, 23
  - outline, 92
  - short description, 1
  - specifications, 89

**C**

- cables
  - Above Deck Unit, 20
  - ground, 120
  - power, 37
- Calibration menu, 52
- company addresses, ii
- contact information, ii
- cradle
  - assembly, F55 Passive, 34
  - assembly, F77 Distress, 28
  - F55 Passive, 2, 33
  - F77 Distress, 2, 27
- cradle/handset Interface, 55

**D**

- Dflt. Setting menu, 52
- dimensions
  - Below Deck Unit, 92
  - Distress Cradle, 97
  - F55 antenna, 85
  - F77 antenna, 86
  - Flange, 87
  - handset, 104
  - Passive Cradle, 100
- discrete I/O interface, 61
- Display Handset
  - short description, 2
- distance
  - ADU to GPS receiver, 12
  - ADU to other Inmarsat antennas, 12
  - ADU to radar, 10
  - ADU to transmitters, 88

Distress Cradle, 27  
assembly, 28  
dimensions, 97  
outline, 97  
short description, 2  
specifications, 95  
document number  
this manual, i

## E

electrostatic discharge  
recommendations, 126  
End Stop Switches  
replacing, 69  
error messages, 71

## F

F55 antenna  
dimensions, 85  
outline, 85  
F55 Passive Cradle, 33  
F77 antenna  
dimensions, 86  
outline, 86  
F77 Distress Cradle, 27  
factory default  
restoring, 52  
fiberglass hulls  
grounding, 116  
Flange  
dimensions, 87  
outline, 87

## G

GMDSS requirements, 3

GPS receiver  
distance from ADU, 12  
grounding, 105  
Above Deck Unit, 19, 111  
aluminum hulls, 114  
Below Deck Unit, 24, 110  
cable, 120  
fiberglass hulls, 116  
marine, 108  
recommendations, 110  
steel hulls, 112  
timber hulls, 118

## H

handset  
dimensions, 104  
outline, 104  
short description, 2  
specifications, 103  
Handset Com Error  
troubleshooting procedure, 75  
handset menu  
Service User, 44  
hardware interfaces  
overview, 53  
Help Desk menu, 47  
High Power Amplifier  
replacing, 66

## I

I/O interface, 61  
IMN Config menu, 49  
installation  
Above Deck Unit, 19  
Below Deck Unit, 23

---

**interfaces**

- analogue 2-wire Interface, 54
- cradle/handset, 55
- discrete I/O, 61
- ISDN, 56
- LAN, 58
- NMEA 0183/2000, 60
- overview, 53
- RS-232, 59
- USB, 57

**interference, 9**

ISDN interface, 56

**L**

LAN interface, 58

LES Config menu, 46

**M****manual**

document number, i

marine grounding, 108

mast for antenna, 14

measuring Ship Source Impedance, 93

**menu**

Calibration, 52

Dflt. Setting, 52

Help Desk, 47

IMN Config, 49

LES Config, 46

PIN Codes, 50

Service User, 44

**menu tree**

Service User, 45

**modules, replacing**

Antenna Control Unit, 67

End Stop Switches, 69

High Power Amplifier, 66

Power Supply Module, 65

Sensor Unit, 68

**N**

NMEA 0183/2000 interface, 60

**O****obstructions**

distance and size, 7

**outline**

Below Deck Unit, 92

Distress Cradle, 97

F55 antenna, 85

F77 antenna, 86

Flange, 87

handset, 104

Passive Cradle, 100

**P**

part numbers, 77

Passive Cradle, 33

assembly, 34

dimensions, 100

outline, 100

short description, 2

specifications, 99

PIN Codes menu, 50

PIN, Service User

changing, 51

- PIN, Super User
  - changing, 50
  - unlocking, 51
- placing the Below Deck Unit, 23
- power
  - cable, 37
  - connecting, 37
  - specification, 41
  - switching off, 44
  - switching on, 43
- Power Supply Module
  - replacing, 65

## R

- radar
  - distance from ADU, 10
- radiation level, 8
- repair, 63
- RF interference
  - recommendations, 125
- RS-232 interface, 59

## S

- safety and warranty, iii
- Sensor Unit
  - replacing, 68
- service, 63
- Service User PIN
  - changing, 51
- setup, 43
- Ship Source Impedance
  - measuring, 93
- spare parts for Above Deck Unit, 64

- specifications
  - Above Deck Unit, 81
  - Below Deck Unit, 89
  - Distress Cradle, 95
  - handset, 103
  - Passive Cradle, 99
- steel hulls
  - grounding, 112
- Super User PIN
  - changing, 50
  - unlocking, 51
- support phone numbers, ii
- system setup, 43
- system units
  - Above Deck Unit, 2
  - Below Deck Unit, 1
  - Display Handset, 2
  - Distress Cradle, 2
  - Passive Cradle, 2

## T

- timber hulls
  - grounding, 118
- troubleshooting, 71

## U

- USB interface, 57